

版本	更改日期	更改内容
01	2025-5-21	用55304-200-720(03)版本更新,改了8.6K/11K27A参数,改了封面。
02	2025-7-12	目录4.7项10改11, 36页4标题重叠字体
03	2025-10-13	用55304-200-626(13)做, 8.6和11K的参数按55304-201-003(02)的
04	2026-1-10	补充设置项描述

制作说明：A4对折

封面纸质：铜板纸

黑白印刷

USER MANUAL

Hybrid

Solar Inverter

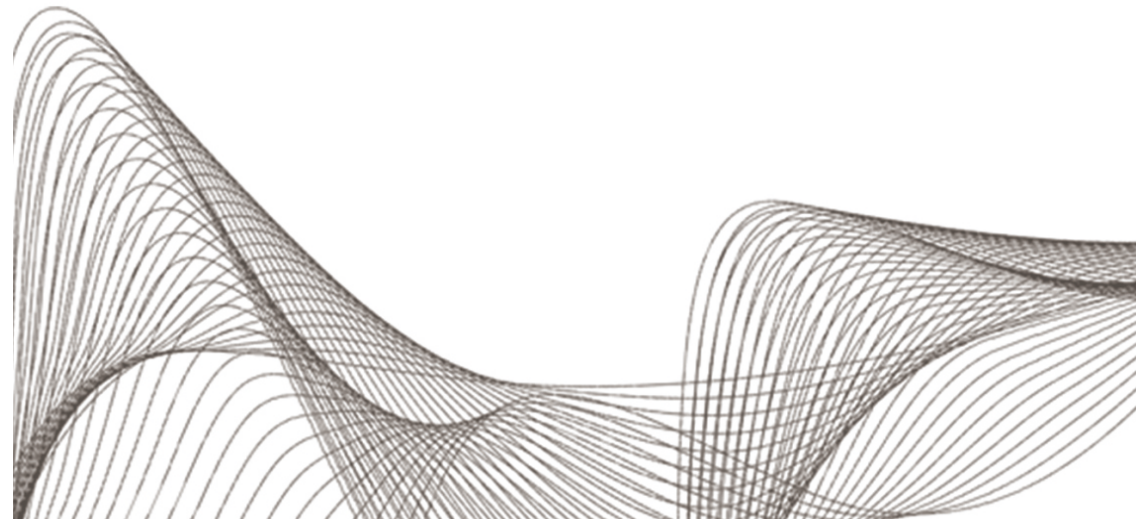

Table Of Contents

1 About This Manual	1
1.1 Purpose.....	1
1.2 Scope.....	1
2 Safety Instructions	1
3 Introduction	2
3.1 Features.....	2
3.2 Basic System Architecture.....	2
3.3 Product Overview.....	3
4 Installation	6
4.1 Unpacking And Inspection	6
4.2 Preparation	6
4.3 Mounting The Unit.....	6
4.4 Battery Connection.....	7
4.5 Ac Input/Output Connection.....	8
4.6 PV Connection.....	9
4.7 Final Assembly.....	11
5 Operation	11
5.1 Power On/off.....	11
5.2 LCD display icon.....	12
5.3 Touch screen flow chart.....	13
5.4 Touch screen operation instructions.....	14
5.5 Fault and alarm description	21
6 Trouble removal	23
7 Technical datasheet	24
Appendix: Parallel function	25
1 Mounting the unit.....	25
2 Wiring Connection.....	25
3 PV Connection.....	35
4 LCD Setting and Display.....	36
5 Commissioning.....	37

5. Commissioning

Parallel in single phase

Step 1: Check the following requirements before commissioning:

- ⌘ Correct wire connection
- ⌘ Ensure all breakers in Line wires of load side are open and each Neutral wires of each unit are connected together.

Step 2: Turn on each unit and Set the output type to "PAL" in the touch screen setting system operating mode of each device. And then shut down all units.

NOET: It's necessary to turn off switch when setting LCD program. Otherwise, the setting can not be programmed.

Step 3: Turn on each unit.

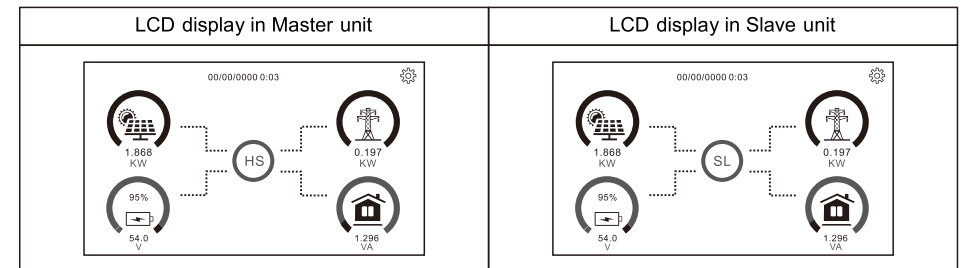

NOTE: Master and slave units are randomly defined.

4.LCD Setting and Display

Setting Program:

Program	Description	Selectable option	
04	AC output mode *This setting is only available when the inverter is in standby mode (Switch off).	Single: SI 0	When the units are used in parallel with single phase, please select "PAL" in output type.
		Parallel: PAL	It is required to have at least 3 inverters or maximum 9 inverters to support three-phase equipment. It's required to have at least one inverter in each phase or it's up to four inverters in one phase please-2 for detailed information. Please select "3P1" in output type for the inverters connected to phase, "3P2" in output type for the inverters connected to L2 phase and "3P3" in output type for the inverters connected to L3 phase. Be sure to connect share current cable to units which are on the same phase. Do NOT connect share current cable between units on different phases. Besides, power saving function will be automatically disabled.
		L1 phase: 3P 1	
		L2 phase: 3P2	
		L3 phase: 3P3	

Fault code display

Fault Code	Fault Event
60	Power feedback protection
71	Firmware version inconsistent
72	Current sharing fault
73	Inconsistent output voltage settings in parallel-connected systems
80	CAN fault
81	Host loss
82	Synchronization loss
83	Battery voltage detected different
84	AC input voltage and frequency detected different
85	AC output current unbalance
86	AC output mode setting is different

1 About This Manual

1.1 Purpose

This manual describes the assembly, installation, operation and troubleshooting of this unit. Please read this manual carefully before installations and operations, Keep manual for future reference.

1.2 Scope

This manual provides safety and installation guidelines as well as information on tools and wiring.

2 Safety Instructions



WARNING: This chapter contains important safety and operating instructions. Read and keep this manual for future reference.

- Before using the unit read all instructions and cautionary markings on the unit, the batteries and all appropriate sections of this manual.
- CAUTION**-To reduce risk of injury, charge only deep-cycle lead acid type rechargeable batteries. Other types of batteries may burst, causing personal injury and damage.
- Do not disassemble the unit Take it to a qualified service center when service or repair is required. Incorrect re-assembly may result in a risk of electric shock or fire.
- To reduce risk of electric shock, disconnect all wirings before attempting any maintenance or cleaning. Turning off the unit will not reduce this risk.
- CAUTION**-Only qualified personnel can install this device with battery.
- NEVER** charge a frozen battery.
- For optimum operation of this inverter/charger, please follow required spec to select appropriate cable size. It's very important to correctly operate this inverter/charger.
- Be very cautious when working with metal tools on or around batteries.A potential risk exists to drop a tool to spark or short circuit batteries or other electrical parts and could cause an explosion.
- Please strictly follow installation procedure when you want to disconnect AC or DC terminals, Please refer to INSTALLATION section of this manual for the details
- One piece of 150A fuse is provided as over-current protection for the battery supply.
- GROUNDING INSTRUCTIONS** -This inverter/ charger should be connected to a permanent grounder wiring system. Be sure to comply with local requirements and regulation to install this inverter.
- NEVER** cause AC output and DC input short circuited. Do NOT connect to the mains when DC input short circuits.
- Warning!!** Only qualified service persons are able to service this device. If errors still persist after following troubleshooting table, please send this inverter/charger back to local dealer or service center for maintenance.

3 Introduction

This is a multi-function Inverter/charger, combining functions of inverter, solar charger and battery charger to offer uninterrupted power support with portable size. Its comprehensive touch screen provides user configurable and easy-to-operate push-button operations. such as battery charging current, AC/solar charger prioritization, and acceptable input voltages based on different loads.

3.1 Features

- ◆ Pure sine wave inverter
- ◆ The input voltage range can be configured for household appliances and personal computers via touch screen Settings
- ◆ Application-based configurable battery charging current setting via touch screen
- ◆ The AC/solar charger priority can be configured through touch screen Settings
- ◆ Compatible to mains voltage or generator power
- ◆ Auto restart while AC is recovering
- ◆ Overload/Over temperature/short circuit protection
- ◆ Smart battery charger design for optimized battery performance
- ◆ Cold start function

3.2 Basic System Architecture

The following illustration shows basic application for this inverter/charger. It also includes following devices to have a complete running system:

- ◆ Generator or Utility
- ◆ PV modules

Consult with your system integrator for other possible system architectures depending on your requirements.

This inverter can power all kinds of appliances in home or environment, including motor-type appliances such as tube light, fan, refrigerator and air conditioner.

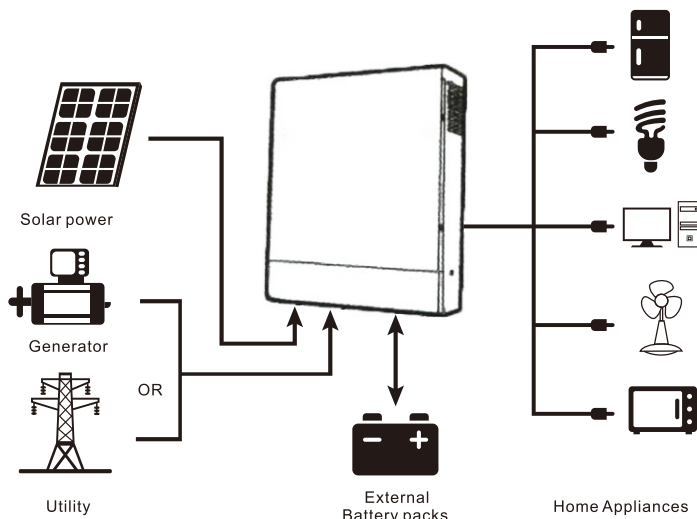

Communication Connection

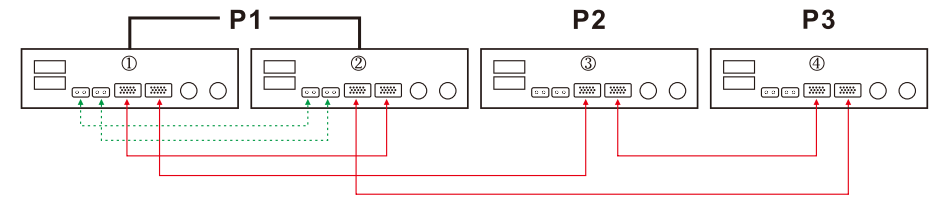

One inverter in each phase:

Power Connection(Each photovoltaic panel needs to be connected to an independent system)

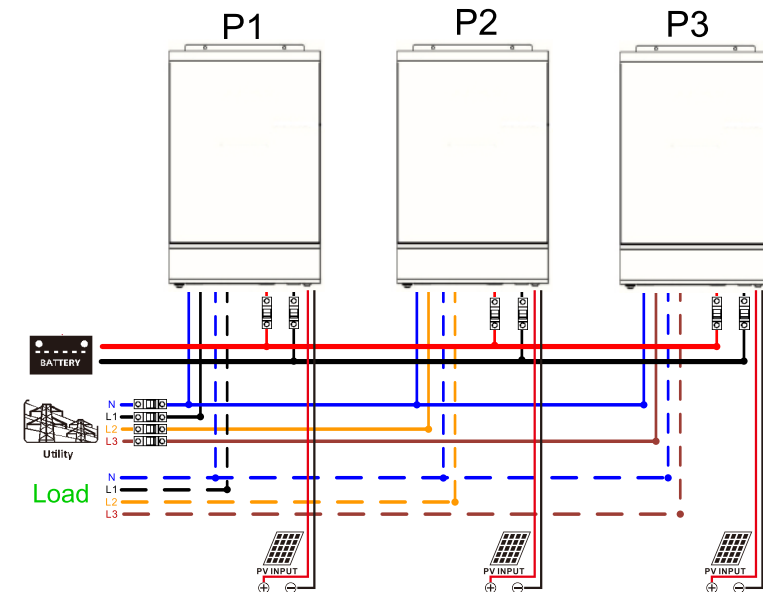

Communication Connection

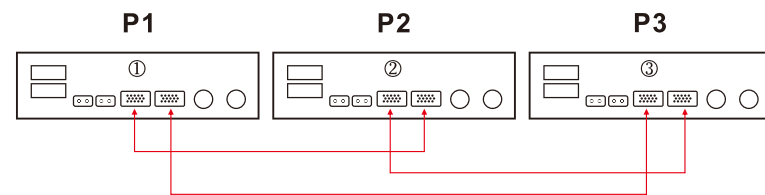

WARNING: Do not connect the current sharing cable between the inverters which are in different phases. Otherwise, it may damage the inverters.

3. PV Connection

Please refer to user manual of single unit for PV Connection
CAUTION: Each inverter should connect to PV modules separately.

Communication Connection

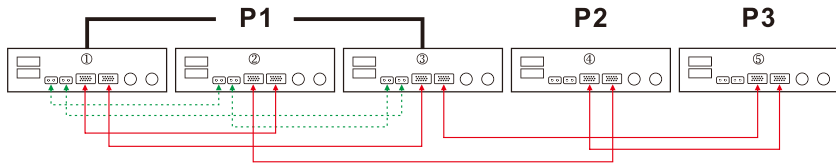

Two inverters in two phases and only one inverter for the remaining phase:

Power Connection(Each photovoltaic panel needs to be connected to an independent system)

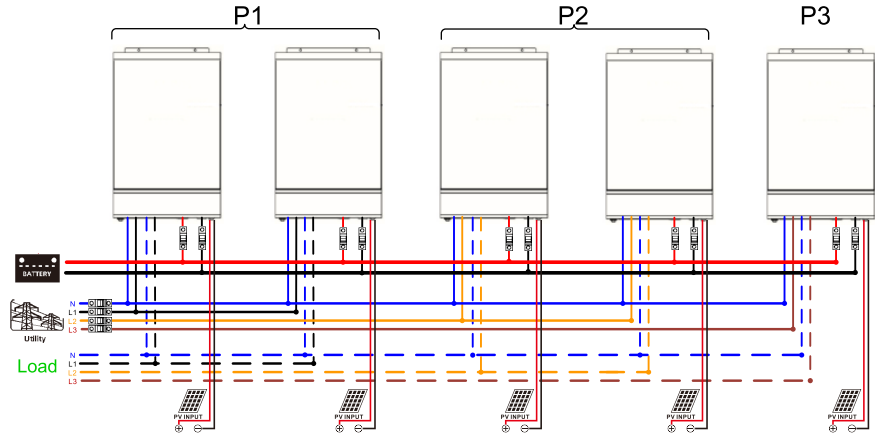

Communication Connection

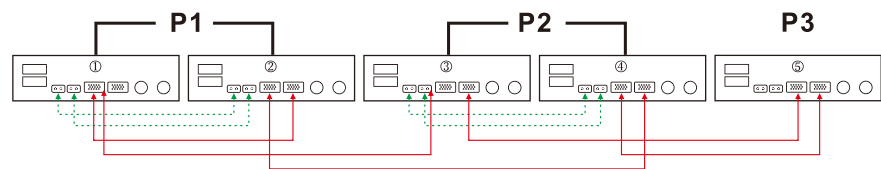

Two inverters in one phase and only one inverter for the remaining phases:

Power Connection(Each photovoltaic panel needs to be connected to an independent system)

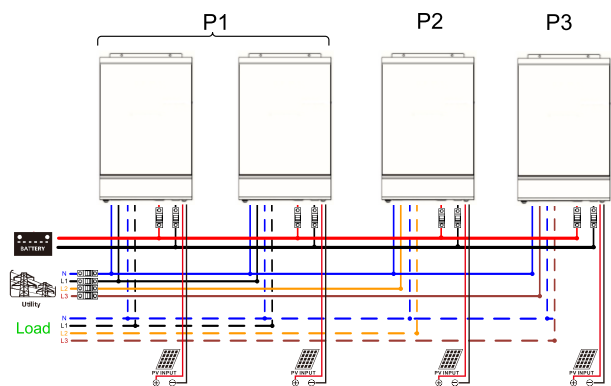

3.3 Product Overview

3.3.1 Touch color screen

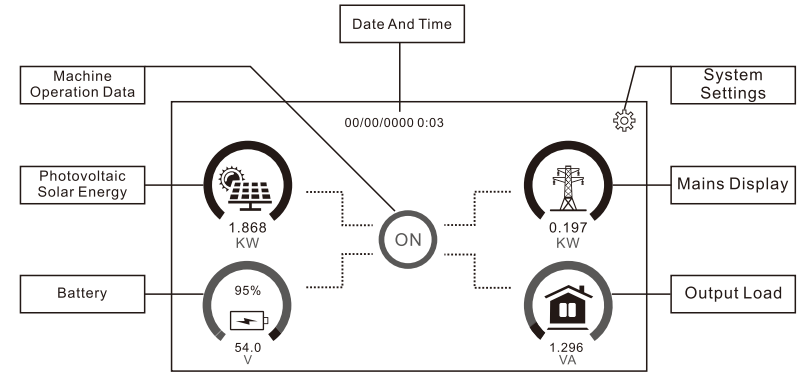

3.3.2 Back Panel

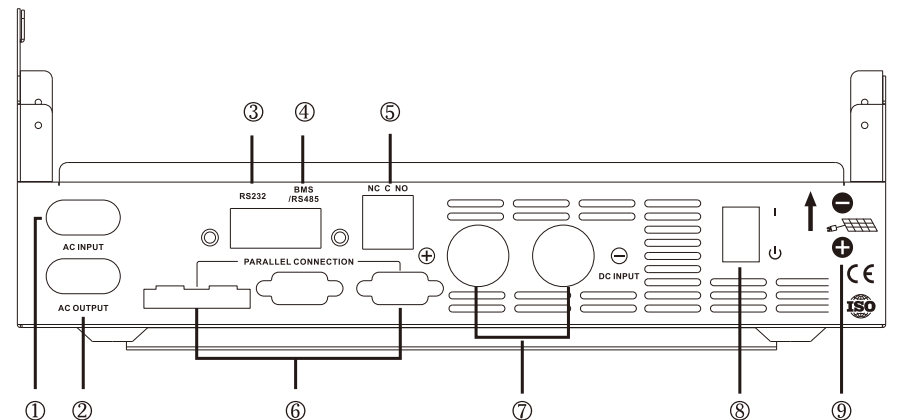
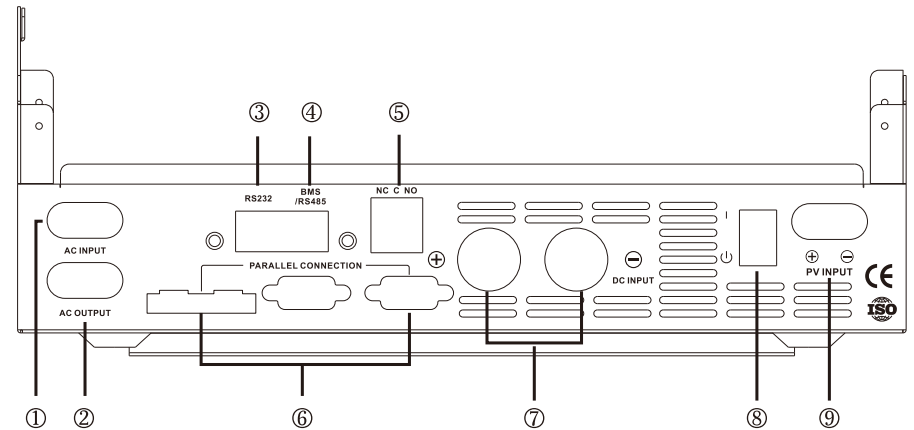

Dual Output Back Panel

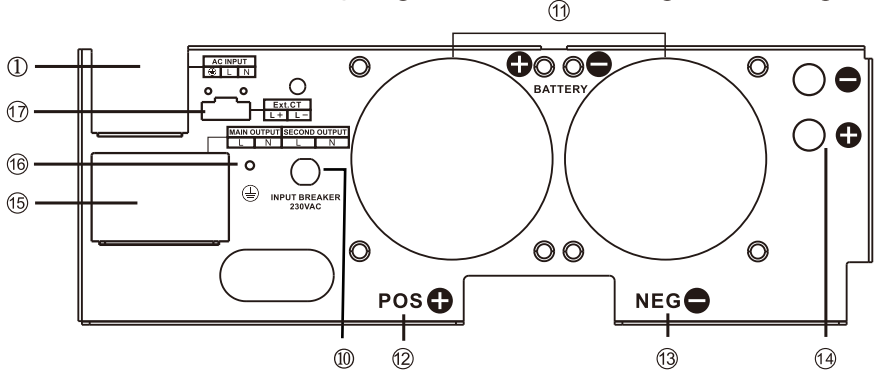
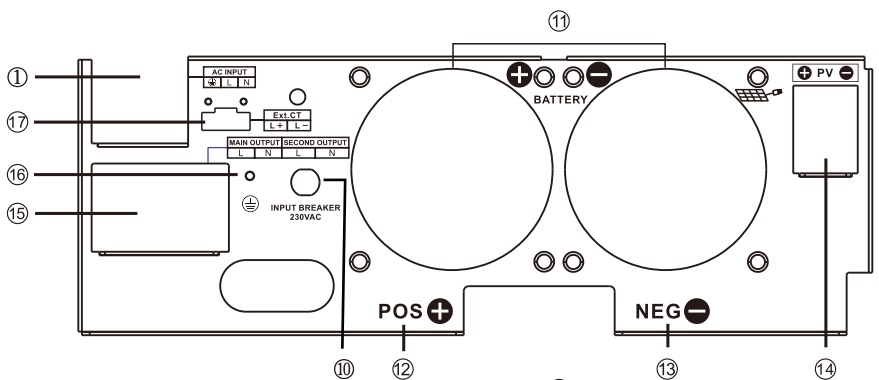
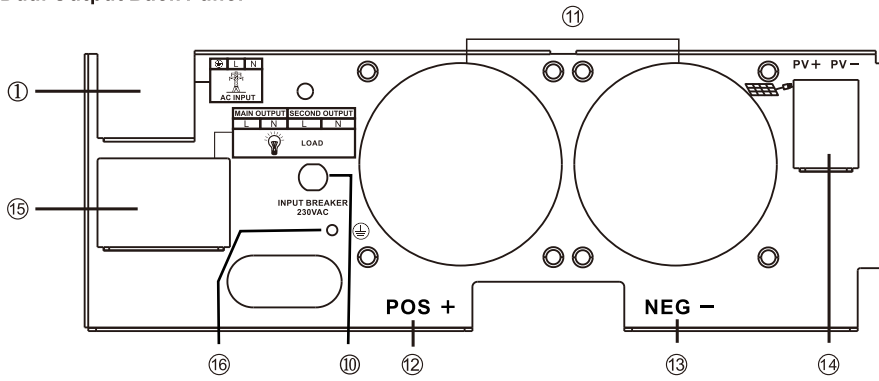

- | | |
|------------------------------------|--------------------------------|
| 1..... AC Input | 10...Input Breaker |
| 2..... AC Output | 11...Fan |
| 3.....Communication Port | 12...Battery Terminal Positive |
| 4.....BMS/RS485 Communication Port | 13...Battery Terminal Negative |
| 5.....Dry Contact | 14...Solar Panel Input |
| 6.....Parallel connection | 15...AC Main/Second Output |
| 7.....Battery Input | 16...Output ground wire |
| 8.....Power ON/ OFF Switch | 17...CT Signal port |
| 9.....PV Input | |

Communication Connection

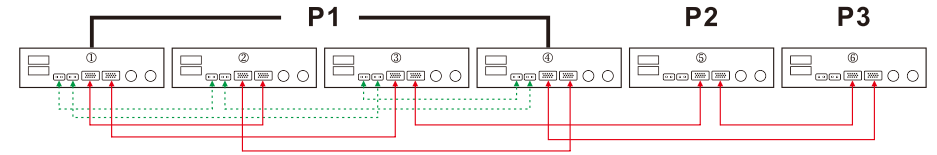

Three inverters in one phase, two inverters in second phase and one inverter for the third phase:

Power Connection(Each photovoltaic panel needs to be connected to an independent system)

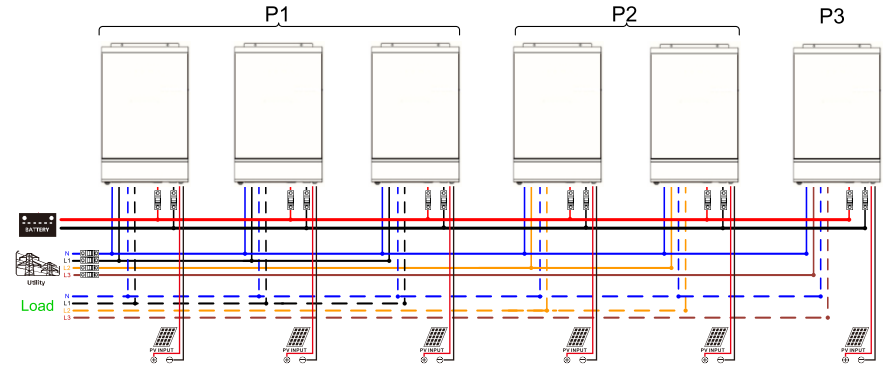

Communication Connection

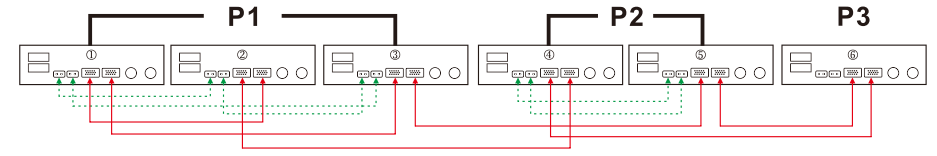

Three inverters in one phase and only one inverter for the remaining two phases:

Power Connection(Each photovoltaic panel needs to be connected to an independent system)

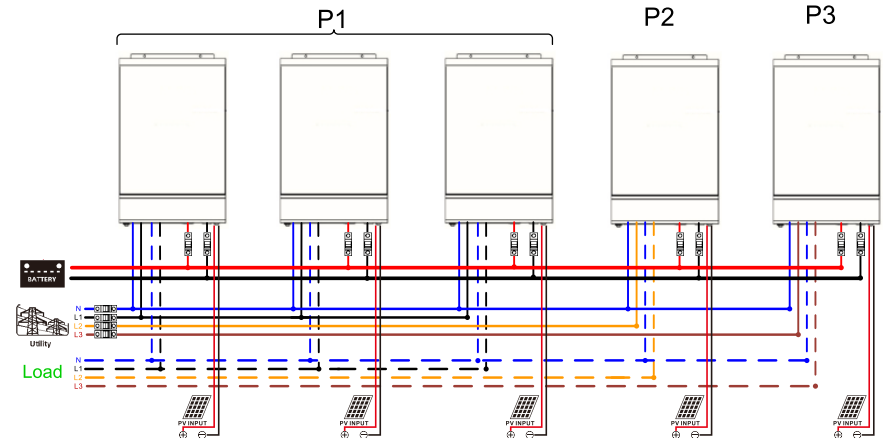

Communication Connection

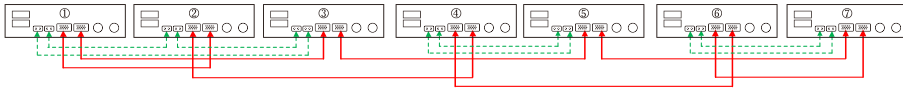

Two inverters in each phase:

Power Connection(Each photovoltaic panel needs to be connected to an independent system)

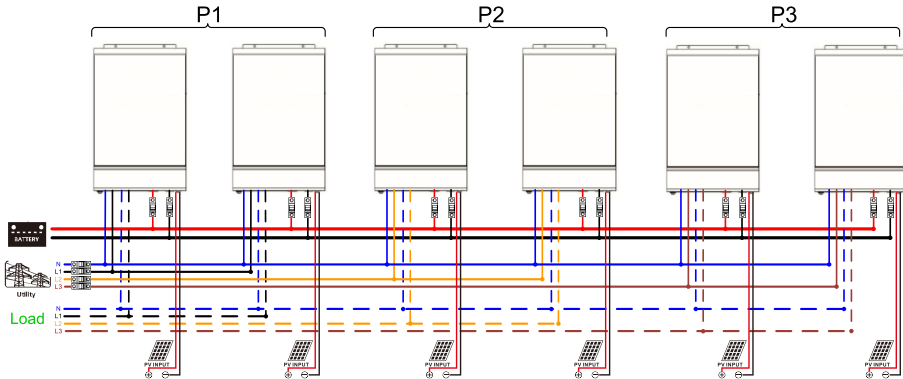

Communication Connection

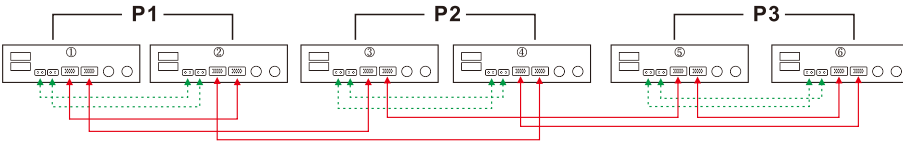

Four inverters in one phase and one inverter for the other two phases:

Power Connection(Each photovoltaic panel needs to be connected to an independent system)

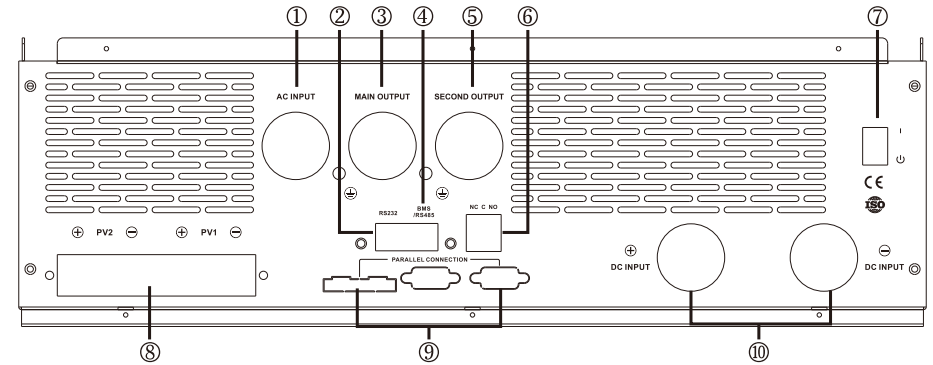
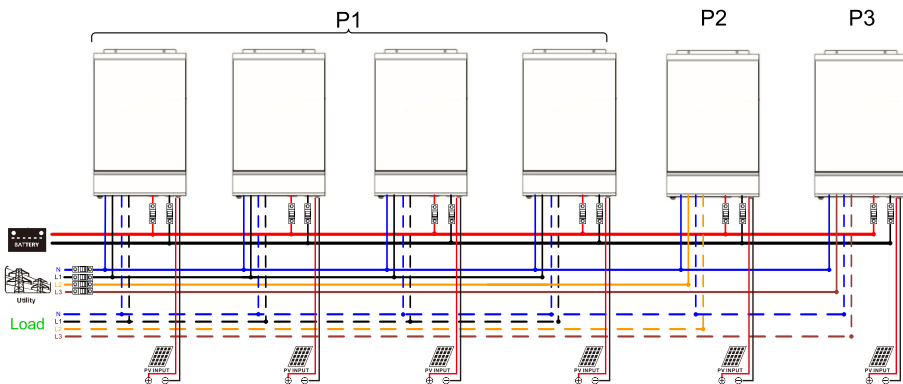

Dual Output Back Panel

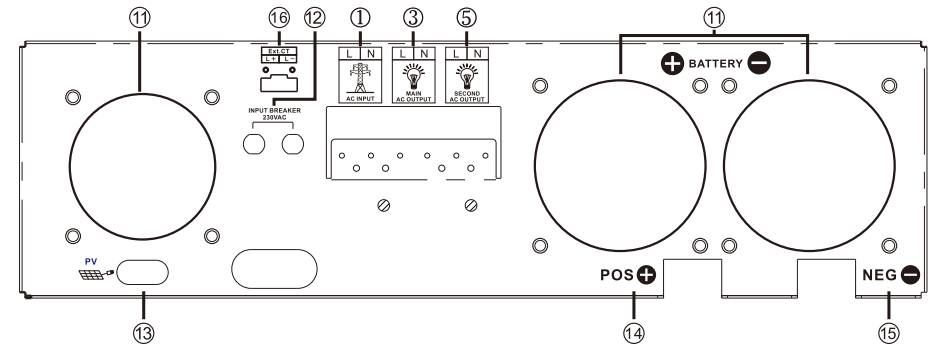
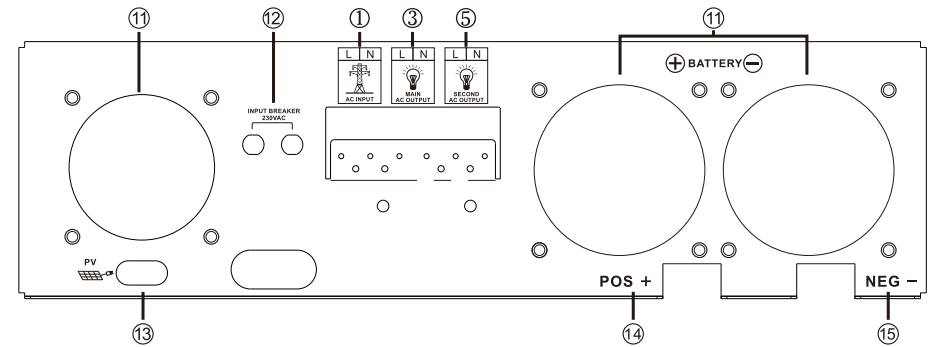

- 1.....AC Input
- 2.....RS232 Communication Port
- 3.....Main output
- 4.....BMS/RS485 Communication Port
- 5.....Second Output
- 6.....Dry Contact
- 7.....Power ON/OFF Switch
- 8.....Solar Panel Input
- 9.....Parallel connection
- 10...Battery Input
- 11...Fan
- 12...Input Breaker
- 13...PV Input
- 14...Battery Terminal Positive
- 15...Battery Terminal Negative
- 16...CT Signal port

4 INSTALLATION

4.1 Unpacking and Inspection

Before installation, please inspect the unit. Be sure that nothing inside the package is damaged. You should have received the following items inside of package:

- ◆ The unit x 1
- ◆ User manual 1

4.2 Preparation

Before connecting all please take off bottom cover by removing two screws as shown below.

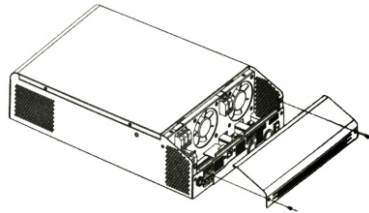

4.3 Mounting the Unit

Consider the following points before selecting where to install:

- ※ Do not mount the inverter on flammable construction materials.
- ※ Mount on a solid surface
- ※ Install this inverter at eye level in order to allow the LCD display to be read at all times.
- ※ For proper air circulation to dissipate heat, allow a clearance of approx. 20 cm to the side and approx. 50 cm above and below the unit.
- ※ The ambient temperature should be within the range of 20-35°C to ensure optimal operation.
- ※ The recommended installation position is to be adhered to the wall vertically.
- ※ Be sure to keep other objects and surfaces as shown in the diagram to guarantee sufficient heat dissipation and to have enough space for removing wires.

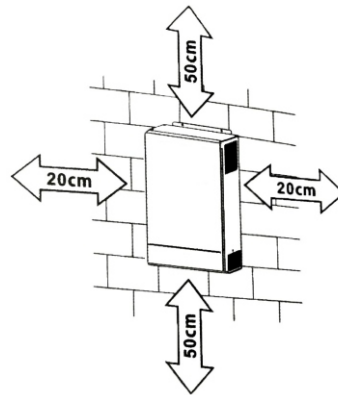

⚠ SUITABLE FOR MOUNTING ON CONCRETE OR OTHER NON-COMBUSTIBLE SURFACE ONLY.

Install the unit by screwing three screws.

- 1,2 Use the M6*80mm expansion bolts.
- 3 Use M4 or M5.



Communication Connection

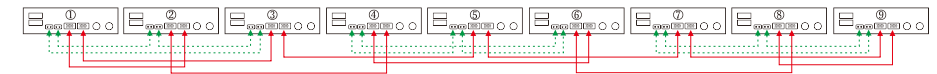

Three inverters in one phase, three inverters in second phase and two inverters for the third phase:

Power Connection(Each photovoltaic panel needs to be connected to an independent system)

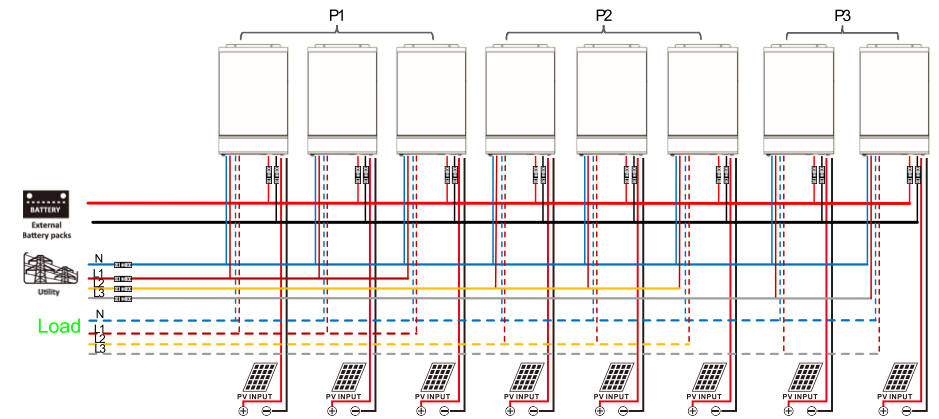

Communication Connection

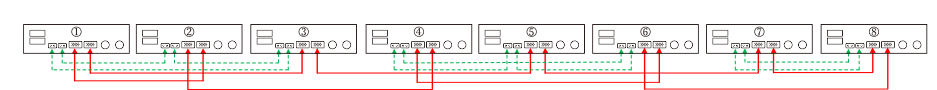

Three inverters in one phase, two inverters in second phase and two inverters for the third phase:

Power Connection(Each photovoltaic panel needs to be connected to an independent system)

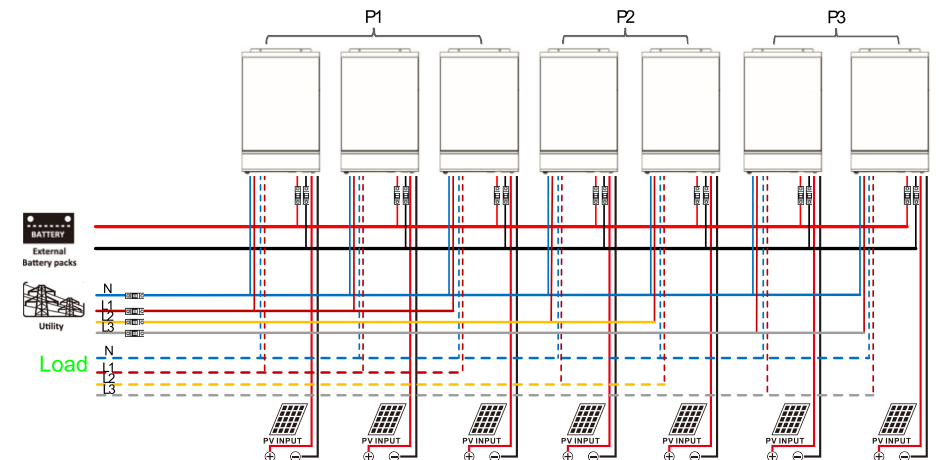

Communication Connection

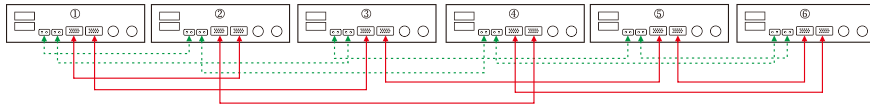

Seven to nine inverters in parallel:

Power Connection(Each photovoltaic panel needs to be connected to an independent system)

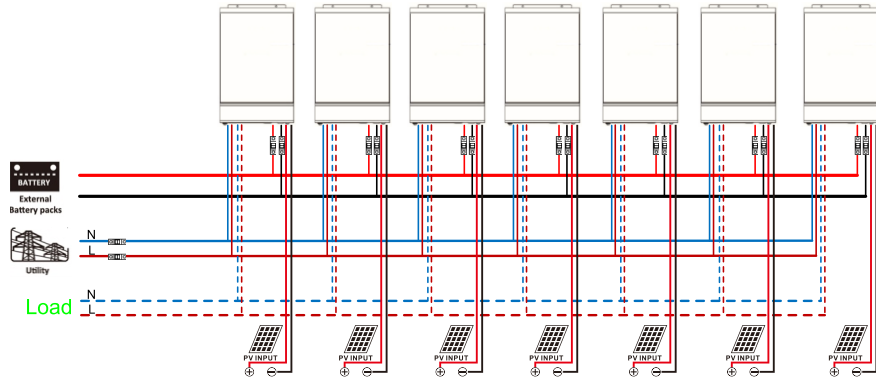

Communication Connection

Seven inverters in parallel

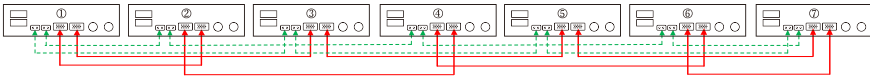

Eight inverters in parallel

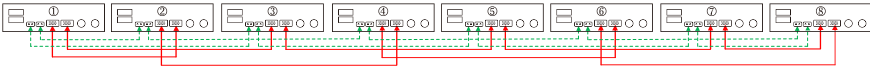

Nine inverters in parallel

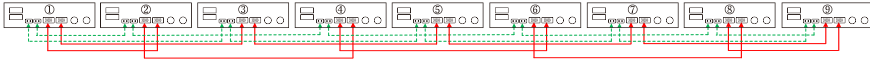

2-2. Support 3-phase equipment

Three inverters in each phase:

Power Connection(Each photovoltaic panel needs to be connected to an independent system)

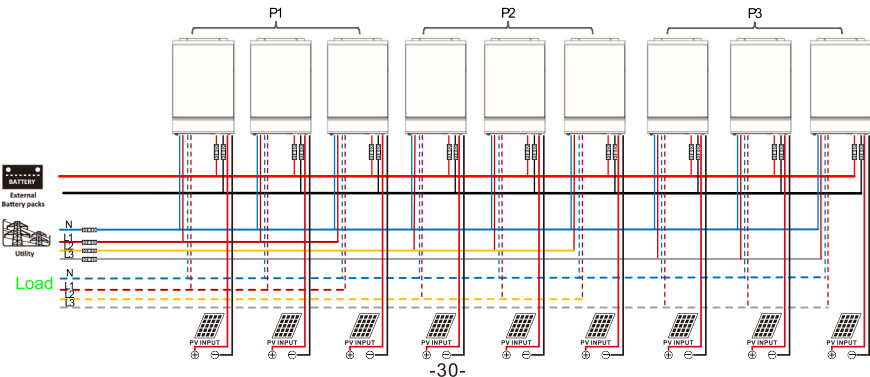

4.4 Battery Connection

CAUTION: For safety operation and regulation compliance, it's requested to install a separate DC over-current protector or disconnect device between battery and inverter. It may not be requested to have a disconnect device in some applications, however, it's still requested to over-current protection installed. Please refer to typical amperage in below table as required fuse or breaker size.

Ring terminal:

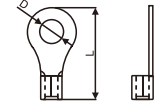

WARNING! All wiring must be performed by qualified personnel.
WARNING! It's very important for system safety and efficient operation to use appropriate cable for battery connection. To reduce risk of injury, please use the proper recommended cable and terminal size as below.

Recommended battery cable and terminal size:

Rated Capacity	Typical Amperage	Battery capacity	Wire Size	Ring Terminal			Torque value
				Cable(mm ²)	Dimensions		
					D(mm)	L(mm)	
3KVA	132A	100AH	1*4AWG	22	6.4	33.2	2~3 Nm
		200AH	2*8AWG	9	6.4	29.2	
3.6KVA	165A	200AH	2*4AWG	25	8.4	33.2	5Nm
4KVA	165A	200AH	2*4AWG	25	8.4	33.2	5Nm
5.5KVA	127A	200AH	1*2AWG	34	6.4	39.2	2~3 Nm
			2*6AWG	14	6.4	33.2	
6.2KVA	143A	200AH	1*2AWG	38	8.4	39.2	5Nm
			2*4AWG	25	8.4	33.2	
8.6KVA	228A	250AH	1*3/0AWG	85	8.4	54	5Nm
11KVA	228A	250AH	1*3/0AWG	85	8.4	54	5Nm

please follow below steps to implement battery connection:

1. Assemble battery ring terminal based on recommended battery cable and terminal size.

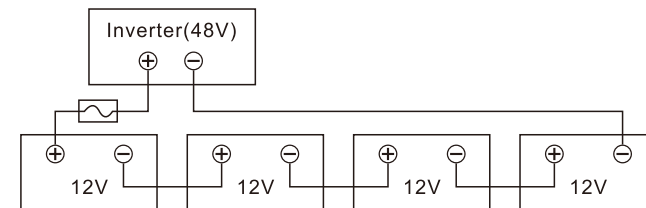
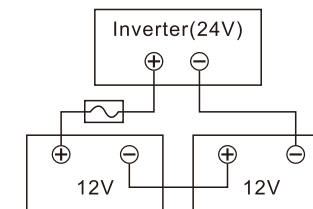

2. Insert the battery wires flatly into battery connectors of inverter and make sure the bolts are tightened with torque of 2 Nm in clockwise direction. Make sure polarity at both the battery and the inverter/charge is correctly connected and conductors are tightly screwed into the battery terminals. Recommended tool: # 2 Pozzi Screwdriver

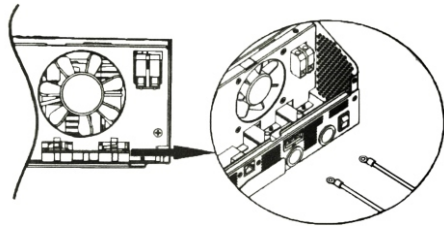

	WARNING: Shock Hazard Installation must be performed with care due to high battery voltage in series.
	CAUTION!! Before making the final DC connection or closing DC breaker/disconnector, be sure positive (+) must be connected to positive (+) and negative (-) must be connected to negative (-).

4.5 AC Input Output Connection

CAUTION!! Before connecting to AC input power source, please Install a separate AC breaker between inverter and AC input power source. This will ensure the Inverter can be disconnected during maintenance and fully protected from over current of AC input. The recommended spec of breaker is 32A for 24V system and 63A for 48V system .

CAUTION!! There are two terminal blocks with " IN " and " OUT " markings. Please do NOT mis-connect input and output connectors.

WARNING! All wiring must be performed by qualified personnel.

WARNING! It's very important for system safety and efficient operation to use appropriate cable for AC input connection. To reduce risk of injury, please use the proper recommended cable size as below.

Suggested cable requirement for AC wires

Rated Capacity	Gauge	Torque value
3KVA	12AWG	1.2~1.6Nm
3.6KVA	12AWG	1.2~1.6Nm
4KVA	12AWG	1.2~1.6Nm
5.5KVA	10AWG	1.4~1.6Nm
6.2KVA	10AWG	1.4~1.6Nm
8.6KVA	8AWG	1.4~1.6Nm
11KVA	8AWG	1.4~1.6Nm

Please follow below steps to implement AC input/ output connection

1. Before making AC input/output connection be sure to open DC protector or disconnector first.
2. Remove insulation sleeve 10mm for six conductors. And shorten phase L and neutral conductor N3 mm.

Communication Connection

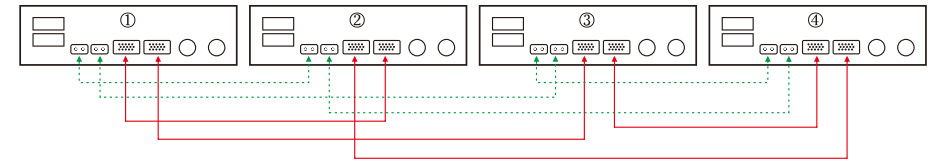

Five inverters in parallel:

Power Connection(Each photovoltaic panel needs to be connected to an independent system)

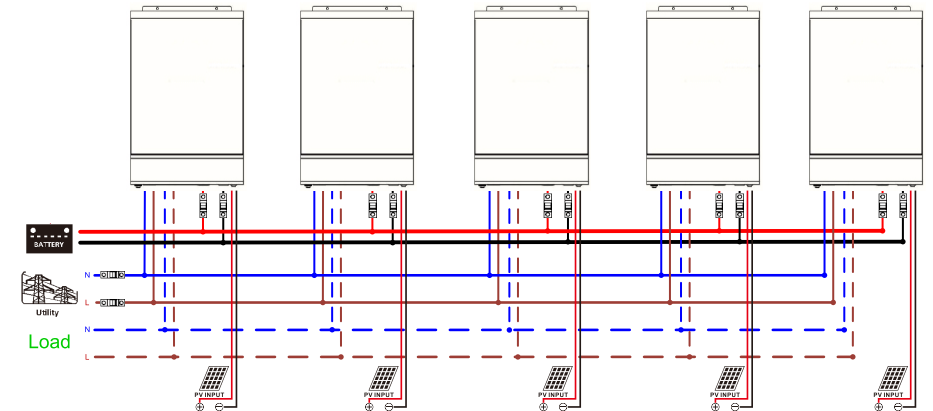

Communication Connection

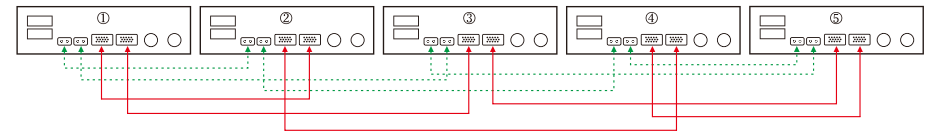

Six inverters in parallel:

Power Connection(Each photovoltaic panel needs to be connected to an independent system)

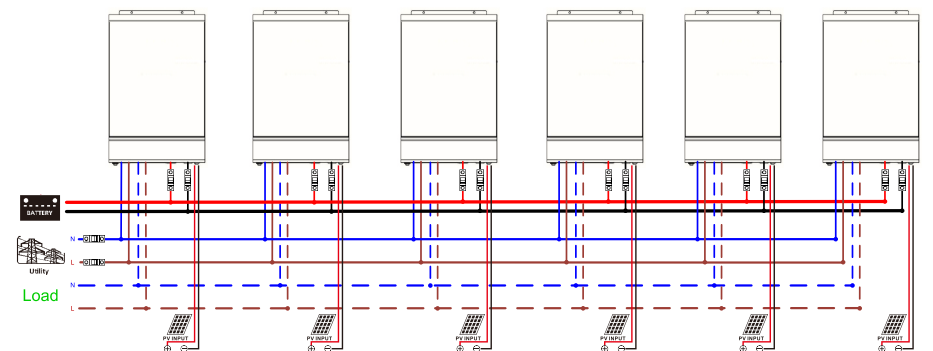

Three inverters in parallel:

Power Connection(Each photovoltaic panel needs to be connected to an independent system)

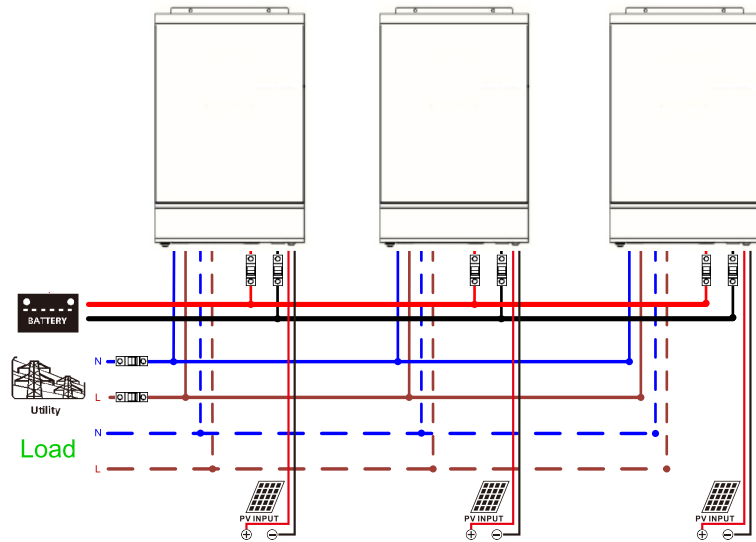

Communication Connection

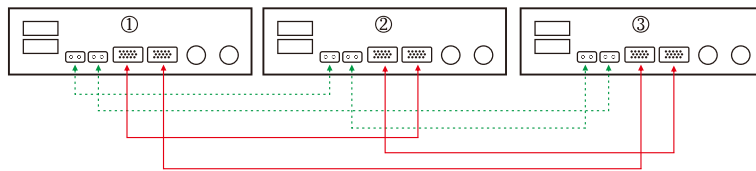

Four inverters in parallel:

Power Connection(Each photovoltaic panel needs to be connected to an independent system)

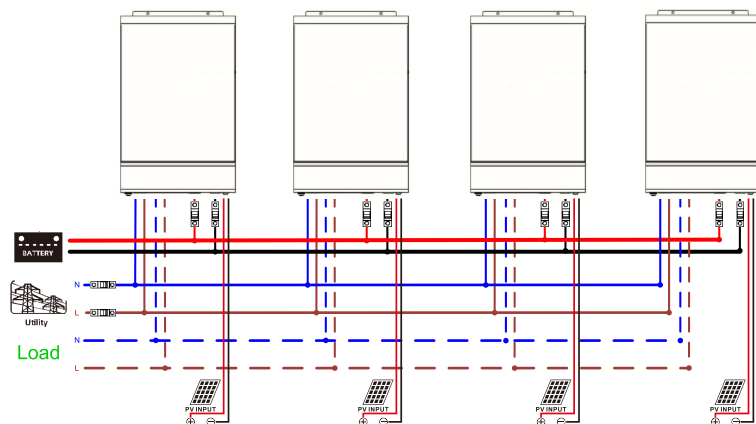

3. Insert AC input wires according to polarities indicated on terminal block and tighten the terminal screws. Be sure to connect PE protective conductor(⊕)first.

- ⊕→Ground(yellow-green)
- L→LINE(brown or black)
- N→Neutral (blue)

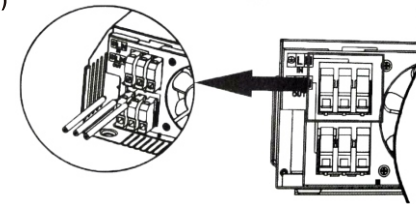

WARNING:
Be sure that AC power source is disconnected before attempting to hardwire it to the unit.

4. Make sure the wires are securely connected

CAUTION: Appliances such as air conditioner are required at least 2~3 minutes to restart because it's required to have enough time to balance refrigerant gas inside of circuits. If a power shortage occurs and recovers in a short time, it will cause damage to your connected appliances. To prevent this kind of damage, please check manufacturer of air conditioner if it's equipped with time-delay function before installation. Otherwise, this inverter/ charger will trig overload fault and cut off output to protect your appliance but sometimes it still causes internal damage to the air conditioner.

4.6 PV Connection

PV Connection(Only apply for the model with solar charger)

CAUTION:Before connecting to PV modules, please install **separately** a DC circuit breaker between inverter and PV modules.

WARNING! All wiring must be performed by a qualified personnel.

WARNING! It's very important for system safety and efficient operation to use appropriate cable for PV module connection. To reduce risk of injury, please use the proper recommended cable size as below.

Typical Amperage	Gauge	Torque Value
30A	12AWG	1.4~1.6Nm

PV module selection:

When choosing the right PV module, be sure to first consider the following requirements:
The open circuit voltage (Voc) of the PV modules does not exceed the maximum PV array open circuit voltage of the inverter. The maximum supply voltage of the PV modules should be close to the optimal PV access voltage range of the inverter for best performance. If one PV module cannot meet this requirement, it is necessary to connect multiple PV modules in series.

Model	3024SMH	3624SMH	4024SMH	5548SMH	6248SMH	8648SMH	11048MH
PV Charging Mode	MPPT	MPPT	MPPT	MPPT	MPPT	MPPT Dual MPPT	MPPT Dual MPPT
MAX.PV Input Power	5000W	6500W	6500W	8500W	8500W	2*6500W	2*7500W
MPPT Tracking Range	60~500Vdc					90~500Vdc	90~500Vdc
Best voltage	300~400V	300~400V	300~400V	360~430V	360~430V	360~430V	360~430V
MAX.PV Input Voltage	500Vdc	500Vdc	500Vdc	500Vdc	500Vdc	500Vdc	500Vdc
PV max input current	18A	27A	27A	27A	27A	27A/27A	27A/27A
MAX.PV Charging Current	100A	120A	120A	100A	120A	150A	150A
MAX.AC Charging Current	60A	100A	100A	100A	100A	150A	150A
MAX.Charging Current	100A	120A	120A	100A	120A	150A	150A

PV Module Wire Connection

Please follow below steps to implement PV module connection:

1. Remove insulation sleeve 10 mm for positive and negative conductors.
2. Suggest to put bootlace ferrules on the end of positive and negative wires with a proper crimping tool
3. Fix wire cover to the inverter with supplied screws as shown in below chart.

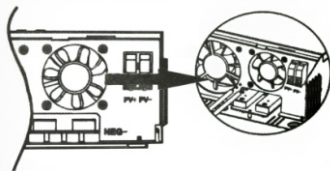
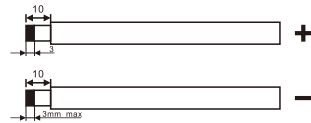

4. Check correct polarity of wire from PV modules and PV input connectors. Then, connect positive pole (+) of connection wire to positive pole (+) of PV input connector. Connect negative pole (-) of connection wire to negative pole (-) of PV input connector. Screw two wires tightly in clockwise direction. Recommended tool: 4mm blade screwdriver.

The CT Operation Guide

With CT connected, hybrid inverter can be easily integrated into the existing household system. It's to arrange self-consumption via CT to control power generation and battery charging of the Inverter.

1. Single commissioning

Step 1. Power off the inverter and connect the external CT by using the tool accessory to install on the spring terminal block. Be noted the mark of current flow direction on the CT should point to the Inverter and the polarity on connecting CT wires on the terminal block should be followed as "L+" VS red wire and "L-" VS black wire.

Step 2. Power on the inverter.

Step 3. Enter LCD setting on the inverter with CT sensor connected and set CT function to "Enable".

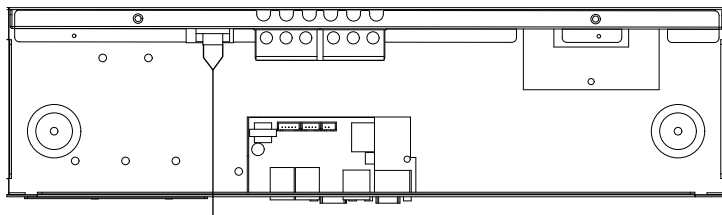

Recommended battery capacity

Inverter parallel numbers	2	3	4	5	6	7	8	9
Battery Capacity for 3KW	400AH	600AH	800AH	1000AH	1200AH	1400AH	1600AH	1800AH
Battery Capacity for 3.6KW	400AH	600AH	800AH	1000AH	1200AH	1400AH	1600AH	1800AH
Battery Capacity for 4KW	400AH	600AH	800AH	1000AH	1200AH	1400AH	1600AH	1800AH
Battery Capacity for 5.5KW	400AH	600AH	800AH	1000AH	1200AH	1400AH	1600AH	1800AH
Battery Capacity for 6.2KW	400AH	600AH	800AH	1000AH	1200AH	1400AH	1600AH	1800AH
Battery Capacity for 8.6KW	500AH	750AH	1000AH	1250AH	1500AH	/	/	/
Battery Capacity for 11KW	500AH	750AH	1000AH	1250AH	1500AH	/	/	/

WARNING! Be sure that all inverters will share the same battery bank. Otherwise, the inverters will transfer to fault mode.

2-1. Parallel operation in single phase

Two inverters in parallel:

Power Connection(Each photovoltaic panel needs to be connected to an independent system)

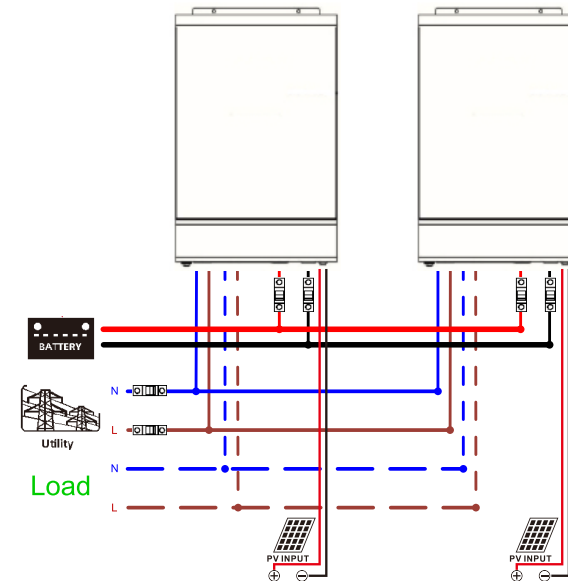

Communication Connection

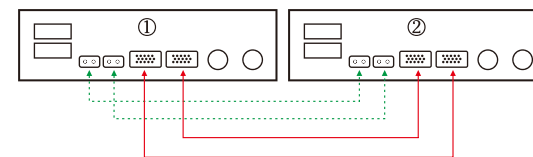

Recommended AC input and output cable size for each inverter:

Rated Capacity	AWG no.	Torque
3KW	12AWG	1.2~1.6Nm
3.6KW	12AWG	1.2~1.6Nm
4KW	12AWG	1.2~1.6Nm
5.5KW	10AWG	1.2~1.6Nm
6.2KW	10AWG	1.2~1.6Nm
8.6KW	8AWG	1.4~1.6Nm
11KW	8AWG	1.4~1.6Nm

You need to connect the cables of each inverter together. Take the battery cables for example: You need to use a connector or bus-bar as a joint to connect the battery cables together, and then connect to the battery terminal. The cable size used from joint to battery should be X times cable size in the tables above. indicates the number of inverters connected in parallel.

Regarding AC input and output, please also follow the same principle.

WARNING!! Make sure all output N wires of each inverter must be connected all the time. Otherwise, it will cause inverter fault in error code #72.

CAUTION!! Please install the breaker at the battery and AC input side. This will ensure the inverter can be securely disconnected during maintenance and fully protected from over current of battery or AC input.

Recommended breaker specification of battery for each inverter:

Rated Capacity	1 unit*	Rated Capacity	1 unit*
3KW	150A/70VDC	6.2KW	150A/70VDC
3.6KW	200A/70VDC	8.6KW	300A/70VDC
4KW	200A/70VDC	11KW	300A/70VDC
5.5KW	150A/70VDC		

*If you want to use only one breaker at the battery side for the whole system, the rating of the breaker should be X times current of 1 unit. "X" indicates the number of inverters connected in parallel.

Recommended breaker specification of AC input with single phase:

Rated Capacity	2 units	3 units	4 units	5 units	6 units	7 units	8 units	9 units
3KW	80A/ 230VAC	120A/ 230VAC	160A/ 230VAC	200A/ 230VAC	240A/ 230VAC	280A/ 230VAC	320A/ 230VAC	360A/ 230VAC
3.6KW	80A/ 230VAC	120A/ 230VAC	160A/ 230VAC	200A/ 230VAC	240A/ 230VAC	280A/ 230VAC	320A/ 230VAC	360A/ 230VAC
4KW	80A/ 230VAC	120A/ 230VAC	160A/ 230VAC	200A/ 230VAC	240A/ 230VAC	280A/ 230VAC	320A/ 230VAC	360A/ 230VAC
5.5KW	80A/ 230VAC	120A/ 230VAC	160A/ 230VAC	200A/ 230VAC	240A/ 230VAC	280A/ 230VAC	320A/ 230VAC	360A/ 230VAC
6.2KW	80A/ 230VAC	120A/ 230VAC	160A/ 230VAC	200A/ 230VAC	240A/ 230VAC	280A/ 230VAC	320A/ 230VAC	360A/ 230VAC
8.6KW	120A/ 230VAC	180A/ 230VAC	240A/ 230VAC	300A/ 230VAC	360A/ 230VAC	/	/	/
11KW	120A/ 230VAC	180A/ 230VAC	240A/ 230VAC	300A/ 230VAC	360A/ 230VAC	/	/	/

Note1: Also, a circuit breaker should be installed at the AC input of each inverter, and the selection of the circuit breaker should refer to the AC input current of the machine nameplate.

Note2: Regarding three-phase system, you can use 4-pole breaker directly and the rating of the breaker should be compatible with the phase current limitation from the phase with maximum units.

4.7 Final Assembly

After connecting all wirings, please put bottom cover back by screwing two screws as shown below.

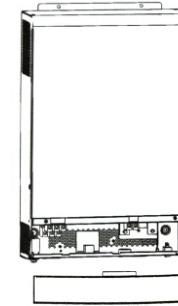

5 OPERATION

5.1 Power ON/OFF

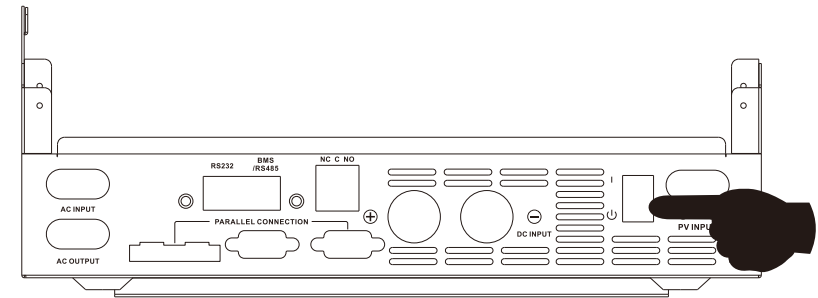

Once the unit has been properly installed and the batteries are connected well, simply press On/Off switch (located on the button of the case) to turn on the unit.

5.1.1 Steps to start up

Connect the battery that meets the requirements (battery voltage needs to be beyond 23V) or AC (AC needs to confirm the suitable input range depends on the output mode), then you can start up the inverter.

➤ Mains power on

Connect to normal AC power, press the switch, the system will automatically turn on. If you set AC output power priority, after waiting for a period of time, the panel will display AC mode that represents turn on the machine successfully, then will enter the AC mode.

When the normal mains power is connected and press the power-on button then the system will automatically power on. If it is set as AC output priority, after a period of time, the panel will display the AC mode to indicate that the power-on is complete and enter the AC mode.

➤ Battery boot

Connect to battery, press the power-on button to establish a working power source.

The system will automatically turn on, after waiting for a period of time, the panel will display battery mode that represents turn on the machine successfully, then will enter the battery mode.

5.1.2 Shutdown steps

When the system is in battery mode or AC mode output, press the switch again, then the system will be turned off.

5.2 LCD display icon

The operation and display panel shown below is located on the front panel of the inverter. It includes an RGB indicators and a LCD display.

5.2.1 Home Screen

The LCD is a touch screen. The upper part of the LCD screen overall information of the inverter.

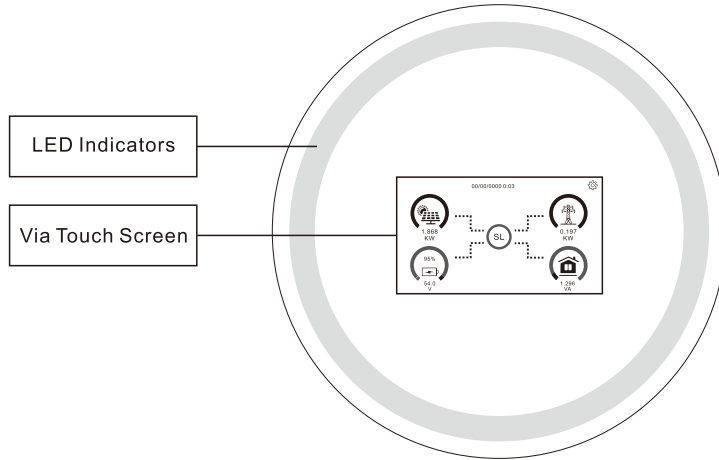

1.The absence of an icon in the center of the home screen indicates that the system is operating normally. If the gray icon and characters are displayed in the center of the main screen, it means that the inverter has an alarm, and the alarm information will be displayed in characters under this icon (detailed error information can be viewed in the instruction manual alarm menu). If the red icon and characters are displayed in the center of the main screen, it means that the inverter is faulty, and the fault information will be displayed in characters under this icon (detailed error information can be viewed in the instruction manual alarm menu).

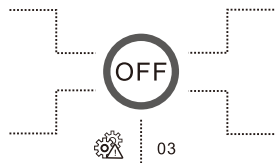

Battery is over charged

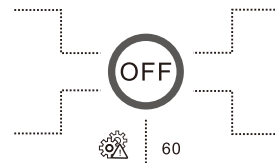

PV voltage is over limitation

2.At the top of the screen is the time.

3.System Settings icon, press the Settings button, you can enter the system Settings screen, including battery Settings, System working mode, grid settings, basic settings, advanced features, device information.

4. The main screen displays information including PV, mains, load and battery. It also shows the direction of energy flow with arrows. Equivalent power. When approaching the limit value, the color on the panel will change from green to red, making the system information vividly displayed on the main screen.

5. Photovoltaic power and load power are always positive.

6. The mains power is connected negatively to the grid and obtained positively.

Appendix I: Parallel function

1. Mounting the unit

When installing multiple units, please follow below chart.

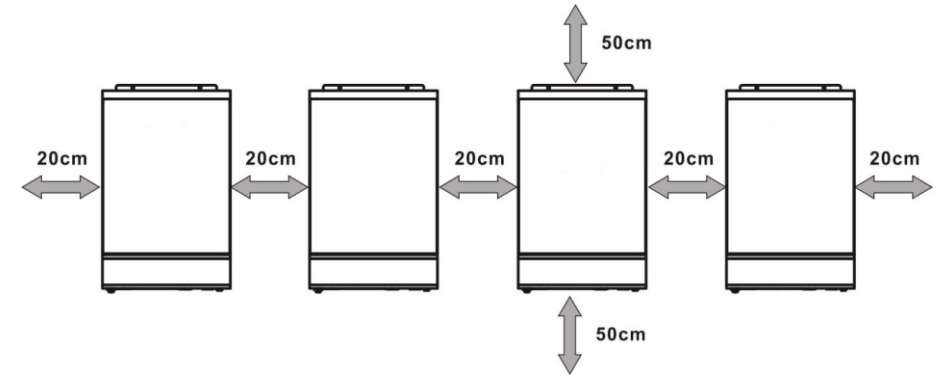

NOTE: For proper air circulation to dissipate heat, allow a clearance of approx. 20 cm to the side and approx.50 cm above and below the unit, Be sure to install each unit in the same level.

2. Wiring Connection

NOTICE: It's requested to connect to battery for parallel operation.

The cable size of each inverter is shown as below:

Recommended battery cable and terminal size for each inverter:

Rated Capacity	Wire Size	Ring Terminal			Torque value	Ring terminal:
		Cable mm ²	Dimensions			
			D (mm)	L (mm)		
3KW	1*4AWG	22	6.4	33.2	2~3Nm	
3.6KW	2*4AWG	25	8.4	33.2	5Nm	
4KW	2*4AWG	25	8.4	33.2	5Nm	
5.5KW	1*2AWG	38	6.4	39.2	2~3Nm	
6.2KW	1*2AWG	38	8.4	39.2	2~3Nm	
8.6KW	1*3/0AWG	85	8.4	54	5Nm	
11KW	1*3/0AWG	85	8.4	54	5Nm	

WARNING: Be sure the length of all battery cables is the same. Otherwise, there will be voltage difference between inverter and battery to cause parallel inverters not working.

7. Technical datasheet

Model		3024SMH	3624SMH	4024SMH	5548SMH	6248SMH	8648SMH	11048MH	
Input	Input Sources	L+N+PE							
	Rated Input Voltage	220/230/240VAC							
	Voltage Range	90-280VAC±3V(APL Mode)170-280VAC±3V(UPS Mode)							
	Frequency	50Hz/60Hz(Auto Adaptive)							
Output	Rated power	The battery inverts	3000W	3600W	4000W	5500W	6200W	8600W	11000W
		Photovoltaic inverter	3600W	4500W	4500W	6500W	6500W	11000W	12000W
	Output Voltage	220/230/240VAC±5%							
	Output Frequency	50/60Hz±0.1%							
	Waveform	Pure Sine Wave							
	Transfer Time (adjustable)	Computers(UPS Mode)10ms, Appliance(APL Mode)20ms							
	Peak Power	6000VA	7200VA	8000VA	11000VA	12400VA	17200VA	22000VA	
	Overload capacity	Battery mode11s@105%~150% Load;2s@150%~200% Load; 400ms@> 200% Load							
Grid-connected operation	Output Voltage	220/230/240VAC±5%							
	Feed into the grid voltage range	100-280VAC							
	Feed into the grid frequency range	47-53±1Hz/57-62±1Hz							
	Nominal output current	13A	15.7A	17.4A	23.9A	26.9A	37.4A	47.8A	
	Power Factor Range	> 0.99							
	Maximum conversion efficiency (DC/AC)	98%							
Battery	Battery Voltage	24Vdc	24Vdc	24Vdc	48Vdc	48Vdc	48Vdc	48Vdc	
	Constant Charging Voltage(Adjustable)	28.2Vdc	28.2Vdc	28.2Vdc	56.4Vdc	56.4Vdc	56.4Vdc	56.4Vdc	
	Floate Charging Voltage(Adjustable)	27Vdc	27Vdc	27Vdc	54Vdc	54Vdc	54Vdc	54Vdc	
Chargers	PV Charging Mode	MPPT	MPPT	MPPT	MPPT	MPPT	MPPT Dual MPPT	MPPT Dual MPPT	
	MAX.PV Input Power	5000W	6500W	6500W	8500W	8500W	2*6500W	2*7500W	
	MPPT Tracking Range	60~500Vdc					90~500Vdc	90~500Vdc	
	Best voltage	300~400V	300~400V	300~400V	360~430V	360~430V	360~430V	360~430V	
	MAX.PV Input Voltage	500Vdc	500Vdc	500Vdc	500Vdc	500Vdc	500Vdc	500Vdc	
	PV max input current	18A	27A	27A	27A	27A	27A/27A	27A/27A	
	MAX.PV Charging Current	100A	120A	120A	100A	120A	150A	150A	
	MAX.AC Charging Current	60A	100A	100A	100A	100A	150A	150A	
MAX.Charging Current	100A	120A	120A	100A	120A	150A	150A		
Display	LCD interface	CAN display running mode/load/input/output, etc.							
Interface	RS232	Baud Rate2400							
	Extend the socket communication interface	Lithium Battery BMS Communication Card WifiCard, Dry Contact							
	Parallel machine interface	No parallel function			Parallel Machine (network) function				
Environments	Operating Temperature	-10~50°C							
	Humidity	20%~95%(Non-condensing)							
	Storage Temperature	-15~60°C							
	Altitude	Altitude Not Over 1000m,Derating over 1000m,Max 4000m. Refer to IEC62040							
	Noise	≤50db							
Standards and certification		EN-IEC 60335-1,EN IEC 60335-2-29, IEC 62109-1							

7. The negative direction of battery power supply means charging, and the positive direction means discharging.

8. LED indicator functions

Code	Machine state	Color	Effect	Breath light
1	Stand by/Self-test	Colorful	Gradient color display	NO
2	Under DC mode	blue	Monochrome display (one light keeps flashing)	NO
3	Under AC/Full charge under AC mode	green	Monochrome display	NO
4	Charging under AC mode	green	Monochrome display	YES
5	Solar charging	yellow	Monochrome display	YES
6	Full charge under solar power	yellow	Monochrome display	NO
7	Under the alarm	red	Monochrome display	YES (recoverable) NO (non-recoverable)
8	Solar energy and AC charging at the same time	half and half	yellow on the top, green at the bottom	YES

5.3 Touch screen flow chart

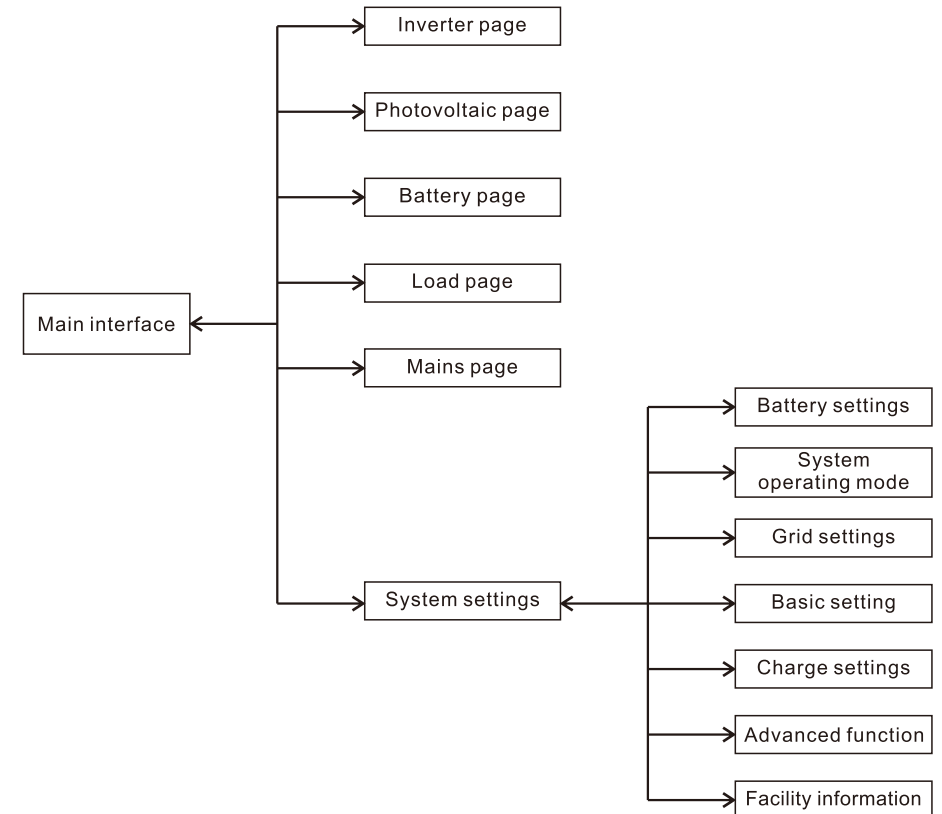

5. 4 Touch screen operation instructions

5.4.1 Touch screen Home screen Content

Inverter page	Inverter data details page
<p>Detail</p> <p>Machine Type: 6248 Lcd Version: V10.01 Inverter Type: HPVINV04 Driver Version: V10.01 Boosting Temp: 31°C Main Version: V10.03 Machine Temp: 51°C MPPT Temp: 25°C MOS Temp: 39°C IAP Status: Normal</p> <p style="text-align: right;">Back</p>	<p>This page shows the inverter machine model, machine type, booster tube temperature, machine temperature, MPPT temperature, inverter temperature, bottom program is normal, color screen version number, central control board version number, machine control board version number.</p>
PV page	PV data details page
<p>Solar</p> <p>PV1 Input: 262.6 V 7.0 A PV1 Input Power: 1855 W PV2 Input: 0.0 V 0.1 A PV2 Input Power: 0 W</p> <p>Today: 0.000KWh Month: 0.0KWh Year: 0.0 KWh Total: 0.0 KWh</p> <p style="text-align: right;">Back</p>	<p>This page shows the input voltage, current and power of photovoltaic solar panels in detail.</p> <p>It can also record today's photovoltaic power generation, this month's photovoltaic power generation, this year's photovoltaic power generation, and the total photovoltaic power generation.</p>
Battery page	Battery details page
<p>Battery</p> <p>Battery Type: AGM BMS COM Function: ON Battery Voltage: 53.0 V Charge Current: 0 A Discharge Current: 0 A Bus Voltage: 370 V Li Battery Active: OFF</p> <p style="text-align: right;">Back</p>	<p>This page shows the battery type, BMS current communication status, battery voltage, BAT charging current, BAT discharge current and BUS voltage in detail and Li Battery Active.</p>
BMS page	BMS details page
<p>BMS</p> <p>BMS 485 Protocol: FEL SOC: 88 % Charge Current: 0.0 A Discharge Current: 1.0 A BMS Temper: 29.0 °C Discharge Limit Voltage: 44.0 V Charge Limit Voltage: 57.6 V Charge Limit Current: 95.0 A</p> <p style="text-align: right;">Back</p>	<p>This page displays the BMS current usage protocol, BMS current SOC value, BMS charging current, BMS discharge current BMS temperature, BMS discharge limit voltage, BMS charge limit voltage, BMS charge limit current in detail.</p> <p>Li Battery Active: Click to activate the lithium battery once.</p> <p>Detail: Click to display cell information.</p>

6. Trouble removal

Problem	LCD/LED/Buzzer	Explanation/Possible cause	What to do
Unit shuts down automatically during startup process.	LCD/LEDs and buzzer will be active for 3 seconds and then complete off.	The battery voltage is too low (<1.91V/Cell)	1. Re-charge battery. 2. Replace battery.
No response after power on.	No indication.	1. The battery voltage is far too low.(<1.4V/Cell) 2. Internal fuse tripped.	1.Contact repair center for replacing the fuse. 2. Re-charge battery. 3. Replace battery.
Mains exist but the unit works in battery mode.	Input voltage is displayed as 0 on the LCD and green LED is flashing.	Input protector is tripped	Check if AC breaker is tripped and AC wiring is connected well.
	Green LED is flashing	Insufficient quality of AC power. (Shore or Generator)	1. Check if AC wires are too thin and/or too long. 2. Check if generator (if applied)is working well or if input voltage range setting is correct.(UP-->splpliance)
When the unit is turned on, internal relay is switched on and off repeatedly.	Green LED is flashing.	Set "Solar First" as the priority of output source.	Change output source priority to Utility first.
	LCD display and LEDs are flashing	Battery is disconnected.	Check if battery wires are connected well.
Buzzer beeps continuously and red LED is on.	Fault code 07	Overload error. The inverter is overload 105% and time is up.	Reduce the connected load by switching off some equipment.
		If PV input voltage is higher than specification, the output power will be derated.At this time, if connected loads is higher than derated output power, it will cause overload.	Reduce the number of PV modules in series or the connected load.
	Fault code 05	Output short circuited.	Check if wiring is connected well and remove abnormal load.
		Temperature internal converter component is over 120°C.	Check whether the air flow of the unit is blocked or whether the ambient temperature is too high.
	Fault code 02	Internal temperature of inverter component is over 100°C	Return to repair center.
	Fault code 03	Battery is over-charged	Return to repair center.
		The battery voltage is too high.	Check if spec and quantity of batteries are meet requirements.
	Fault code 01	Fan fault	Replace the fan.
	Fault code 06/58	Output abnormal (Inverter voltage below than 190Vac or is higher than 260Vac)	1. Reduce the connected load. 2. Return to repair center
	Fault code 08/09/53/57	Internal components failed.	Return to repair center.
Fault code 51	Over current or surge.	Restart the unit, if the error happens again, please return to repair center.	
Fault code 52	Bus voltage is too low.		
Fault code 55	Output voltage is unbalanced.	Reduce the number of PV modules in series.	
Fault code 59	PV input voltage is beyond the specification.		

5.5.2 Alarm Descriptions

➤ **Alarm:** The red LED flashes, and the LCD displays an alarm code, the inverter does not enter the failure mode

Alarm Indicator

Alarm Code	Alarm Event	Audible Alarm
01	Fan is locked when inverter is on.	Beep three times every second
02	Over temperature	None
03	Battery is over-charged	Beep once every second
04	Low battery	Beep once every second
07	Overload	Beep once every 0.5 second
10	Output power derating	Beep twice every 3 seconds
15	PV energy is low.	Beep twice every 3 seconds
16	High AC input (>280VAC) during BUS soft start	None
E9	Battery equalization	None
bP	Battery is not connected	None

5.5.3 Code Reference

Related information code will be displayed on LCD screen. Please check inverter LCD screen for the operation.

Code	Description
60	If battery status is not allowed to charge and discharge after the communication between the inverter and battery is successful, it will show code 60 to stop charging and discharging battery.
61	Communication lost <ul style="list-style-type: none"> After battery is connected, communication signal is not detected for 1 minutes, buzzer will beep. Communication lost occurs after the inverter and battery is connected successfully, buzzer beeps immediately.
69	If battery status is not allowed to charge after the communication between the inverter and battery is successful, it will show code 69 to stop charging battery.
70	If battery status must to charge after the communication between the inverter and battery is successful, it will show code 70 to charge battery.
71	If battery status is not allowed to discharge after the communication between the inverter and battery is successful, it will show code 71 to stop discharge battery.

Load page	Load detail page
	This page displays the output mode, output voltage, output frequency, active power, reactive power in detail.
Mains page	Mains details page
	This page displays the frequency, input voltage, and power of the grid
CT page	CT details page
	This page displays the frequency, input voltage, and power of the grid at the CT detection point

5.4.2 System Settings menu

System Settings menu	System Settings menu page
	This is the system Settings page, including battery Settings, system working mode, battery Settings, mains Settings, charging Settings, basic Settings, advanced functions, device information

Basic Settings menu	Basic Settings menu page																								
<div style="border: 1px solid black; padding: 5px;"> <p>Basic Setting</p> <table border="1"> <thead> <tr> <th>Setting Parameter</th> <th>Current Value</th> <th>Set Value</th> <th></th> </tr> </thead> <tbody> <tr> <td>Output Voltage</td> <td>230V</td> <td>230V</td> <td><input checked="" type="checkbox"/></td> </tr> <tr> <td>Output Frequency</td> <td>50Hz</td> <td>50Hz</td> <td><input checked="" type="checkbox"/></td> </tr> <tr> <td>Alarm Control</td> <td>ON</td> <td>ON</td> <td><input checked="" type="checkbox"/></td> </tr> <tr> <td>Over Load Bypass</td> <td>OFF</td> <td>OFF</td> <td><input checked="" type="checkbox"/></td> </tr> <tr> <td>Over Load Restart</td> <td>OFF</td> <td>OFF</td> <td><input checked="" type="checkbox"/></td> </tr> </tbody> </table> <p style="text-align: right;">Basic Setting page 1/2</p> </div>	Setting Parameter	Current Value	Set Value		Output Voltage	230V	230V	<input checked="" type="checkbox"/>	Output Frequency	50Hz	50Hz	<input checked="" type="checkbox"/>	Alarm Control	ON	ON	<input checked="" type="checkbox"/>	Over Load Bypass	OFF	OFF	<input checked="" type="checkbox"/>	Over Load Restart	OFF	OFF	<input checked="" type="checkbox"/>	<p>This page can be set Inverter voltage: 220/230/240V(default 230V) Inverter frequency: 50/60HZ(default 50HZ) Alarm Control: ON/OFF Over Load Bypass: ON/OFF Over Load Restart: ON/OFF</p>
Setting Parameter	Current Value	Set Value																							
Output Voltage	230V	230V	<input checked="" type="checkbox"/>																						
Output Frequency	50Hz	50Hz	<input checked="" type="checkbox"/>																						
Alarm Control	ON	ON	<input checked="" type="checkbox"/>																						
Over Load Bypass	OFF	OFF	<input checked="" type="checkbox"/>																						
Over Load Restart	OFF	OFF	<input checked="" type="checkbox"/>																						
<div style="border: 1px solid black; padding: 5px;"> <p>Basic Setting</p> <table border="1"> <thead> <tr> <th>Setting Parameter</th> <th>Current Value</th> <th>Set Value</th> <th></th> </tr> </thead> <tbody> <tr> <td>MIP Cut Off Buz</td> <td>ON</td> <td>ON</td> <td><input checked="" type="checkbox"/></td> </tr> <tr> <td>Over Temp Restart</td> <td>OFF</td> <td>OFF</td> <td><input checked="" type="checkbox"/></td> </tr> <tr> <td>Auto Back Menu</td> <td>ON</td> <td>ON</td> <td><input checked="" type="checkbox"/></td> </tr> </tbody> </table> <p style="text-align: right;">Basic Setting page 2/2</p> </div>	Setting Parameter	Current Value	Set Value		MIP Cut Off Buz	ON	ON	<input checked="" type="checkbox"/>	Over Temp Restart	OFF	OFF	<input checked="" type="checkbox"/>	Auto Back Menu	ON	ON	<input checked="" type="checkbox"/>	<p>This page can be set MIP Cut Off Buz: ON/OFF Over Temp Restart: ON/OFF Auto Back Menu: ON/OFF</p>								
Setting Parameter	Current Value	Set Value																							
MIP Cut Off Buz	ON	ON	<input checked="" type="checkbox"/>																						
Over Temp Restart	OFF	OFF	<input checked="" type="checkbox"/>																						
Auto Back Menu	ON	ON	<input checked="" type="checkbox"/>																						
Battery Settings menu	Battery Settings menu page																								
<div style="border: 1px solid black; padding: 5px;"> <p>Battery Setting</p> <table border="1"> <thead> <tr> <th>Setting Parameter</th> <th>Current Value</th> <th>Set Value</th> <th></th> </tr> </thead> <tbody> <tr> <td>Battery Type</td> <td>AGM</td> <td>AGM</td> <td><input checked="" type="checkbox"/></td> </tr> <tr> <td>Bulk Charging VOL</td> <td>56.4V</td> <td>56.4V</td> <td><input checked="" type="checkbox"/></td> </tr> <tr> <td>Float Charging VOL</td> <td>54.0V</td> <td>54.0V</td> <td><input checked="" type="checkbox"/></td> </tr> <tr> <td>Battery Cut-off VOL</td> <td>42.0V</td> <td>42.0V</td> <td><input checked="" type="checkbox"/></td> </tr> <tr> <td>Battery Low VOL</td> <td>44.0V</td> <td>44.0V</td> <td><input checked="" type="checkbox"/></td> </tr> </tbody> </table> <p style="text-align: right;">Battery Setting page 1/4</p> </div>	Setting Parameter	Current Value	Set Value		Battery Type	AGM	AGM	<input checked="" type="checkbox"/>	Bulk Charging VOL	56.4V	56.4V	<input checked="" type="checkbox"/>	Float Charging VOL	54.0V	54.0V	<input checked="" type="checkbox"/>	Battery Cut-off VOL	42.0V	42.0V	<input checked="" type="checkbox"/>	Battery Low VOL	44.0V	44.0V	<input checked="" type="checkbox"/>	<p>This page can be set Battery Type: AGM/FLD/USE/PYL/LIA/LIB/LIC/GRO/TQF/FEL AGM: (default) FLD: Flooded USE: User-Defined. If "User-Defined" is selected, Bulk Charging VOL, Float Charging VOL, Battery Cut-off VOL and Dual BAT VOL Under can be set up. If "PYL/LIA/TQF/GRO/FEL" is selected, Bulk Charging VOL, Float Charging VOL and Battery Cut-off VOL can be set up. No need for further setting. "LIB" if using Lithium battery compatible to Lib protocol. Bulk Charging VOL, Float Charging VOL and Battery Cut-off VOL can be set up. No need for further setting. If "LIC" is selected, Bulk Charging VOL, Float Charging VOL, Battery Cut-off VOL will be automatically set up. No need for further setting. Please contact the battery supplier for installation procedure. Bulk Charging VOL: If you select Custom in the battery type, you can set the program. The Settings range for 24V system is 24.0V-30.0V, and the Settings range for 48V system 48.0V-60.0V Float Charging VOL: 27V/54V Battery Cut-off VOL: If battery power is the only power available, the converter will shut down. If PV energy and battery power are available, the inverter will charge the battery without AC output. If Custom is selected in the battery type, you can set the program.</p>
Setting Parameter	Current Value	Set Value																							
Battery Type	AGM	AGM	<input checked="" type="checkbox"/>																						
Bulk Charging VOL	56.4V	56.4V	<input checked="" type="checkbox"/>																						
Float Charging VOL	54.0V	54.0V	<input checked="" type="checkbox"/>																						
Battery Cut-off VOL	42.0V	42.0V	<input checked="" type="checkbox"/>																						
Battery Low VOL	44.0V	44.0V	<input checked="" type="checkbox"/>																						

Communication Connection

Please use supplied communication cable to connect to inverter and PC. Please install a monitoring software on the computer.

Dry Contact Signal

There is one dry contact (3A/250VAC) available on the rear panel. It could be used to deliver signal to external device when battery voltage reaches warning level.

Unit Status	Condition	Dry contact port: NC C NO			
		NC & C	NC & C		
Power Off	Unit is off and no output is powered.	Close	Open		
Power On	Output is powered from battery or solar.	Normal mode	Battery voltage < Low DC warning voltage	Open	Close
			Battery voltage > Float charging voltage	Close	Open
		Solar first mode	Battery voltage < Solar to AC voltage	Open	Close
			Battery voltage > AC to DC voltage	Close	Open

5.5 Fault and alarm description

5.5.1 Faults Descriptions

➤ **Fault:** The inverter enters the fault mode, the red LED light is always on and the LCD displays the fault code.

Fault Reference Code

Fault Code	Fault Event
01	Fan is locked when inverter is off.
02	Over temperature or NTC is not connected well.
03	Battery voltage is too high.
04	Battery voltage is too low.
05	Output short circuited or over temperature is detected by internal converter components.
06	Output voltage is too high.
07	Over load time out.
08	Bus voltage is too high
09	Bus soft start failed
51	Over currents or surge
52	Bus voltage is too low
53	Inverter soft start failed
55	Over DC voltage in AC output
57	Current sensor failed
58	Output voltage is too low
59	PV voltage is over limitation

Advanced Settings menu	Advanced Settings menu page																								
<p>Advanced Function</p> <table border="1"> <thead> <tr> <th>Setting Parameter</th> <th>Current Value</th> <th>Set Value</th> <th></th> </tr> </thead> <tbody> <tr> <td>Dual Mode</td> <td>ON</td> <td>ON</td> <td><input checked="" type="checkbox"/></td> </tr> <tr> <td>Dual BAT VOL Under</td> <td>44.0V</td> <td>44.0V</td> <td><input checked="" type="checkbox"/></td> </tr> <tr> <td>Dual BAT SOC Under</td> <td>20%</td> <td>20%</td> <td><input checked="" type="checkbox"/></td> </tr> <tr> <td>Dual BAT VOL Receiver</td> <td>52.0V</td> <td>52.0V</td> <td><input checked="" type="checkbox"/></td> </tr> <tr> <td>Dual BAT SOC Receiver</td> <td>50%</td> <td>50%</td> <td><input checked="" type="checkbox"/></td> </tr> </tbody> </table> <p>Adv page 1/3</p>	Setting Parameter	Current Value	Set Value		Dual Mode	ON	ON	<input checked="" type="checkbox"/>	Dual BAT VOL Under	44.0V	44.0V	<input checked="" type="checkbox"/>	Dual BAT SOC Under	20%	20%	<input checked="" type="checkbox"/>	Dual BAT VOL Receiver	52.0V	52.0V	<input checked="" type="checkbox"/>	Dual BAT SOC Receiver	50%	50%	<input checked="" type="checkbox"/>	<p>This page can be set</p> <p>Dual mode: ON/OFF</p> <p>Dual BAT VOL Under: 44V/22V, if the battery voltage is lower than the inverter setting, the dual output is cut off.</p> <p>Dual BAT SOC Under: Default 20%, if the BMS capacity is lower than the SOC setting the second output will be cut.</p> <p>Dual BAT VOL Receiver: Default 52V/26V, if the battery voltage is higher than the inverter setting, the dual will be restored.</p> <p>Dual BAT SOC Receiver: Default 50%, if the BMS capacity is higher than the SOC setting, the second output will be restored.</p>
Setting Parameter	Current Value	Set Value																							
Dual Mode	ON	ON	<input checked="" type="checkbox"/>																						
Dual BAT VOL Under	44.0V	44.0V	<input checked="" type="checkbox"/>																						
Dual BAT SOC Under	20%	20%	<input checked="" type="checkbox"/>																						
Dual BAT VOL Receiver	52.0V	52.0V	<input checked="" type="checkbox"/>																						
Dual BAT SOC Receiver	50%	50%	<input checked="" type="checkbox"/>																						
<p>Advanced Function</p> <table border="1"> <thead> <tr> <th>Setting Parameter</th> <th>Current Value</th> <th>Set Value</th> <th></th> </tr> </thead> <tbody> <tr> <td>Dual Discharge Time</td> <td>Disable</td> <td>0min</td> <td><input checked="" type="checkbox"/></td> </tr> <tr> <td>Dual Recover Delay Time</td> <td>5 Min</td> <td>5 Min</td> <td><input checked="" type="checkbox"/></td> </tr> <tr> <td>Dual Output On Time</td> <td>0:00</td> <td>0:00</td> <td><input checked="" type="checkbox"/></td> </tr> <tr> <td>Dual Output Off Time</td> <td>0:00</td> <td>0:00</td> <td><input checked="" type="checkbox"/></td> </tr> </tbody> </table> <p>Adv page 2/3</p>	Setting Parameter	Current Value	Set Value		Dual Discharge Time	Disable	0min	<input checked="" type="checkbox"/>	Dual Recover Delay Time	5 Min	5 Min	<input checked="" type="checkbox"/>	Dual Output On Time	0:00	0:00	<input checked="" type="checkbox"/>	Dual Output Off Time	0:00	0:00	<input checked="" type="checkbox"/>	<p>This page can be set</p> <p>Dual Discharge Time: The value ranges from 0-990min Configure Discharge Time to turn off second output, and waiting time to turn on the second output when the inverter is back to Line mode or Battery is in charging status.</p> <p>Dual Recover Delay Time: Configure the second output recovery delay. Even if Dual BAT VOL Receiver and Dual BAT SOC Receiver conditions are met, enable the second output after the recovery delay ends, The value ranges from 0-60min.</p> <p>Dual Output On Time: The value ranges from 0 to 23.</p> <p>Dual Output Off Time: The value ranges from 0 to 23.</p>				
Setting Parameter	Current Value	Set Value																							
Dual Discharge Time	Disable	0min	<input checked="" type="checkbox"/>																						
Dual Recover Delay Time	5 Min	5 Min	<input checked="" type="checkbox"/>																						
Dual Output On Time	0:00	0:00	<input checked="" type="checkbox"/>																						
Dual Output Off Time	0:00	0:00	<input checked="" type="checkbox"/>																						
<p>Advanced Function</p> <table border="1"> <thead> <tr> <th>Setting Parameter</th> <th>Current Value</th> <th>Set Value</th> <th></th> </tr> </thead> <tbody> <tr> <td>Output Open Time</td> <td>0:00</td> <td>0:00</td> <td><input checked="" type="checkbox"/></td> </tr> <tr> <td>Output Stop Time</td> <td>0:00</td> <td>0:00</td> <td><input checked="" type="checkbox"/></td> </tr> </tbody> </table> <p>Adv page 3/3</p>	Setting Parameter	Current Value	Set Value		Output Open Time	0:00	0:00	<input checked="" type="checkbox"/>	Output Stop Time	0:00	0:00	<input checked="" type="checkbox"/>	<p>This page can be set</p> <p>Output Open Time: The value ranges from 0 to 23.</p> <p>Output Stop Time: The value ranges from 0 to 23.</p>												
Setting Parameter	Current Value	Set Value																							
Output Open Time	0:00	0:00	<input checked="" type="checkbox"/>																						
Output Stop Time	0:00	0:00	<input checked="" type="checkbox"/>																						
Device information setting menu	Device information setting menu page																								
<p>Device Info</p> <p>System Time: 0000-00-00 00:09</p> <p>2000 Year 0 Month 0 Day 0 H 9 M 0 S <input checked="" type="checkbox"/></p> <p>Back Light: <input checked="" type="checkbox"/></p> <p>RGB Switch: <input checked="" type="checkbox"/> ON</p>	<p>This page can be set</p> <p>System time: year/month/day/hour/minute /second.</p> <p>Back Light: From dark to light.</p> <p>RGB Switch: ON/OFF</p>																								

When the BMS/485 communication interface is externally connected, as shown in the following figure:

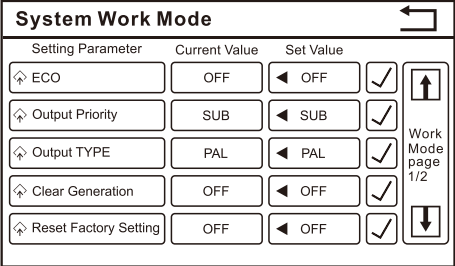
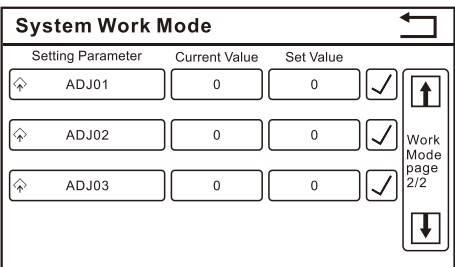

	<p>24V system are set from 20.0V-26.0V</p> <p>48V system are set from 40.0V-52.0V</p> <p>and the Battery Cut-off VOL will be fixed at the set value regardless of the proportion of load connected.</p> <p>Battery Low VOL: 24V system are set from 20.0V-27.0V, 48V system are set from 40.0V-54.0V</p>																								
<p>Battery Setting</p> <table border="1"> <thead> <tr> <th>Setting Parameter</th> <th>Current Value</th> <th>Set Value</th> <th></th> </tr> </thead> <tbody> <tr> <td>BMS Function Switch</td> <td>OFF</td> <td>OFF</td> <td><input checked="" type="checkbox"/></td> </tr> <tr> <td>BMS SOC Under Lock</td> <td>10%</td> <td>10%</td> <td><input checked="" type="checkbox"/></td> </tr> <tr> <td>BMS SOC Turn To AC</td> <td>20%</td> <td>20%</td> <td><input checked="" type="checkbox"/></td> </tr> <tr> <td>BMS SOC Turn To DC</td> <td>95%</td> <td>95%</td> <td><input checked="" type="checkbox"/></td> </tr> <tr> <td>BMS Restart SOC</td> <td>50%</td> <td>50%</td> <td><input checked="" type="checkbox"/></td> </tr> </tbody> </table> <p>Battery Setting page 2/4</p>	Setting Parameter	Current Value	Set Value		BMS Function Switch	OFF	OFF	<input checked="" type="checkbox"/>	BMS SOC Under Lock	10%	10%	<input checked="" type="checkbox"/>	BMS SOC Turn To AC	20%	20%	<input checked="" type="checkbox"/>	BMS SOC Turn To DC	95%	95%	<input checked="" type="checkbox"/>	BMS Restart SOC	50%	50%	<input checked="" type="checkbox"/>	<p>This page can be set</p> <p>BMS Function Switch: Whether to enable the BMS communication function.</p> <p>BMS SOC Under Lock: The SOC value of the BMS falls below the set value and the inverter shuts down to protect the battery.</p> <p>BMS SOC Turn To AC: When the inverter operating mode is set to battery priority mode, when the BMS SOC is below the set value, the inverter will be forced to enter the power supply to charge.</p> <p>BMS SOC Turn To DC: When the inverter works in battery priority mode, the inverter works in DC mode when the BMS SOC is higher than the set value.</p> <p>BMS Restart SOC: When the inverter is turned on, the SOC must be higher than the set value to work properly.</p>
Setting Parameter	Current Value	Set Value																							
BMS Function Switch	OFF	OFF	<input checked="" type="checkbox"/>																						
BMS SOC Under Lock	10%	10%	<input checked="" type="checkbox"/>																						
BMS SOC Turn To AC	20%	20%	<input checked="" type="checkbox"/>																						
BMS SOC Turn To DC	95%	95%	<input checked="" type="checkbox"/>																						
BMS Restart SOC	50%	50%	<input checked="" type="checkbox"/>																						
<p>Battery Setting</p> <table border="1"> <thead> <tr> <th>Setting Parameter</th> <th>Current Value</th> <th>Set Value</th> <th></th> </tr> </thead> <tbody> <tr> <td>Battery Equalization</td> <td>OFF</td> <td>OFF</td> <td><input checked="" type="checkbox"/></td> </tr> <tr> <td>BAT EQ Voltage</td> <td>58.4V</td> <td>58.4V</td> <td><input checked="" type="checkbox"/></td> </tr> <tr> <td>BAT EQ Time</td> <td>60 Min</td> <td>60Min</td> <td><input checked="" type="checkbox"/></td> </tr> <tr> <td>BAT EQ Out Time</td> <td>120 Min</td> <td>120Min</td> <td><input checked="" type="checkbox"/></td> </tr> <tr> <td>BAT EQ Interval</td> <td>30 Day</td> <td>30Day</td> <td><input checked="" type="checkbox"/></td> </tr> </tbody> </table> <p>Battery Setting page 3/4</p>	Setting Parameter	Current Value	Set Value		Battery Equalization	OFF	OFF	<input checked="" type="checkbox"/>	BAT EQ Voltage	58.4V	58.4V	<input checked="" type="checkbox"/>	BAT EQ Time	60 Min	60Min	<input checked="" type="checkbox"/>	BAT EQ Out Time	120 Min	120Min	<input checked="" type="checkbox"/>	BAT EQ Interval	30 Day	30Day	<input checked="" type="checkbox"/>	<p>This page can be set</p> <p>Battery Equalization: You can set this program if you select "Liquid Battery" or "User Defined" in the battery type.</p> <p>BAT EQ Voltage: 29.2V for 24V system, 58.4V for 48V system,</p> <p>BAT EQ Time: The value ranges from 5 minutes to 900 minutes.</p> <p>BAT EQ Out Time: The value ranges from 5 minutes to 900 minutes.</p> <p>BAT EQ Interval: The value ranges from 0 to 90 days.</p>
Setting Parameter	Current Value	Set Value																							
Battery Equalization	OFF	OFF	<input checked="" type="checkbox"/>																						
BAT EQ Voltage	58.4V	58.4V	<input checked="" type="checkbox"/>																						
BAT EQ Time	60 Min	60Min	<input checked="" type="checkbox"/>																						
BAT EQ Out Time	120 Min	120Min	<input checked="" type="checkbox"/>																						
BAT EQ Interval	30 Day	30Day	<input checked="" type="checkbox"/>																						
<p>Battery Setting</p> <table border="1"> <thead> <tr> <th>Setting Parameter</th> <th>Current Value</th> <th>Set Value</th> <th></th> </tr> </thead> <tbody> <tr> <td>DC TO AC Voltage</td> <td>46.0V</td> <td>46.0V</td> <td><input checked="" type="checkbox"/></td> </tr> <tr> <td>AC TO DC Voltage</td> <td>54.0V</td> <td>54.0V</td> <td><input checked="" type="checkbox"/></td> </tr> </tbody> </table> <p>Battery Setting page 4/4</p>	Setting Parameter	Current Value	Set Value		DC TO AC Voltage	46.0V	46.0V	<input checked="" type="checkbox"/>	AC TO DC Voltage	54.0V	54.0V	<input checked="" type="checkbox"/>	<p>This page can be set</p> <p>DC TO AC voltage: 22V-25.5V/44V-51V</p> <p>AC TO DC voltage: 24V-29/48V-58V</p>												
Setting Parameter	Current Value	Set Value																							
DC TO AC Voltage	46.0V	46.0V	<input checked="" type="checkbox"/>																						
AC TO DC Voltage	54.0V	54.0V	<input checked="" type="checkbox"/>																						

System working mode setting menu	System working mode setting menu page																								
	<p>This page can be set</p> <p>ECO function: Under the battery model, when the load is low, the system will temporarily stop.</p> <p>Output priority: Output source priority option.</p> <p>1.SUB: Solar energy as the first priority for the load, if the solar energy is not enough to supply all connected loads, the utility grid energy will supply the load at the same time. Solar power as the first priority provides power for the load output source priority selection.</p> <p>2.SBU: If the solar energy is not enough to supply all the connected loads, the battery energy will supply the loads simultaneously. The mains supplies power to the load only when the battery voltage drops to a low level warning voltage or when the solar and battery are insufficient.</p> <p>Output TYPE: SIG/PAL/3P1/3P2/3P3</p> <p>AC output mode: This setting is only available when the inverter is in standby mode (Switch off). When the units are used in parallel with single phase, please select "PAL" in Output TYPE. It is required to have at least 3 inverters or maximum 9 inverters to support three-phase equipment. It's required to have at least one inverter in each phase or it's up to four inverters in one phase please -2 for detailed information. Please select "3P1" in Output TYPE for the inverters connected to phase, "3P2" in Output TYPE for the inverters connected to L2 phase and "3P3" in Output TYPE for the inverters connected to L3 phase. Be sure to connect share current cable to units which are on the same phase. Do NOT connect share current cable between units on different phases. Besides, power saving function will be automatically disabled.</p> <p>Clear Generation: OFF/ON Remove the power generation capacity: tick the check box and click "YES".</p> <p>Reset Factory Setting: To restore the default values, tick the check box and click "YES".</p>																								
 <p>System Work Mode</p> <table border="1"> <thead> <tr> <th>Setting Parameter</th> <th>Current Value</th> <th>Set Value</th> <th></th> </tr> </thead> <tbody> <tr> <td>ECO</td> <td>OFF</td> <td>OFF</td> <td><input checked="" type="checkbox"/></td> </tr> <tr> <td>Output Priority</td> <td>SUB</td> <td>SUB</td> <td><input checked="" type="checkbox"/></td> </tr> <tr> <td>Output TYPE</td> <td>PAL</td> <td>PAL</td> <td><input checked="" type="checkbox"/></td> </tr> <tr> <td>Clear Generation</td> <td>OFF</td> <td>OFF</td> <td><input checked="" type="checkbox"/></td> </tr> <tr> <td>Reset Factory Setting</td> <td>OFF</td> <td>OFF</td> <td><input checked="" type="checkbox"/></td> </tr> </tbody> </table> <p>Work Mode page 1/2</p>	Setting Parameter	Current Value	Set Value		ECO	OFF	OFF	<input checked="" type="checkbox"/>	Output Priority	SUB	SUB	<input checked="" type="checkbox"/>	Output TYPE	PAL	PAL	<input checked="" type="checkbox"/>	Clear Generation	OFF	OFF	<input checked="" type="checkbox"/>	Reset Factory Setting	OFF	OFF	<input checked="" type="checkbox"/>	
Setting Parameter	Current Value	Set Value																							
ECO	OFF	OFF	<input checked="" type="checkbox"/>																						
Output Priority	SUB	SUB	<input checked="" type="checkbox"/>																						
Output TYPE	PAL	PAL	<input checked="" type="checkbox"/>																						
Clear Generation	OFF	OFF	<input checked="" type="checkbox"/>																						
Reset Factory Setting	OFF	OFF	<input checked="" type="checkbox"/>																						
 <p>System Work Mode</p> <table border="1"> <thead> <tr> <th>Setting Parameter</th> <th>Current Value</th> <th>Set Value</th> <th></th> </tr> </thead> <tbody> <tr> <td>ADJ01</td> <td>0</td> <td>0</td> <td><input checked="" type="checkbox"/></td> </tr> <tr> <td>ADJ02</td> <td>0</td> <td>0</td> <td><input checked="" type="checkbox"/></td> </tr> <tr> <td>ADJ03</td> <td>0</td> <td>0</td> <td><input checked="" type="checkbox"/></td> </tr> </tbody> </table> <p>Work Mode page 2/2</p>	Setting Parameter	Current Value	Set Value		ADJ01	0	0	<input checked="" type="checkbox"/>	ADJ02	0	0	<input checked="" type="checkbox"/>	ADJ03	0	0	<input checked="" type="checkbox"/>	<p>This page is reserved for future functions.</p>								
Setting Parameter	Current Value	Set Value																							
ADJ01	0	0	<input checked="" type="checkbox"/>																						
ADJ02	0	0	<input checked="" type="checkbox"/>																						
ADJ03	0	0	<input checked="" type="checkbox"/>																						

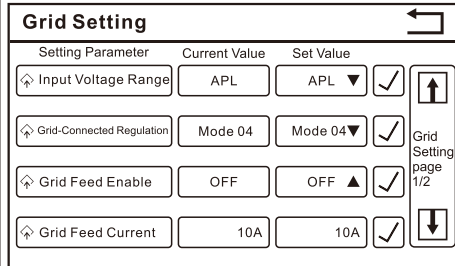
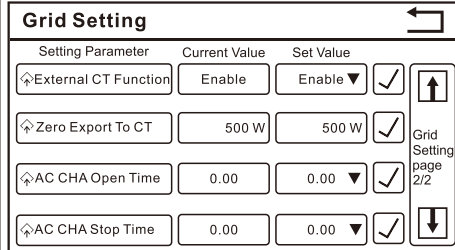
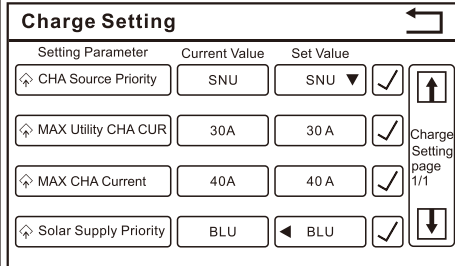
Mains grid Settings menu	Mains grid Settings menu page																				
	<p>This page can be set</p> <p>Input Voltage Range: APL/UPS APL: The value ranges from 90-280VAC UPS: The value ranges from 170-280VAC</p> <p>Grid-Connected Regulation: Mode 01/ Mode 02/Mode 03/Mode 04/Mode 05</p> <p>Mode 1: Acceptable feed-in grid voltage range will be 195.5-253VAC. Acceptable feed-in grid frequency range will be 49-51Hz.</p> <p>Mode 2: Acceptable feed-in grid voltage range will be 184-264.5VAC. Acceptable feed-in grid frequency range will be 47.5-51.5Hz.</p> <p>Mode 3: Acceptable feed-in grid voltage range will be 184-264.5VAC. Acceptable feed-in grid frequency range will be 57-62Hz.</p> <p>Mode 4: Acceptable feed-in grid voltage range will be 170-264.5VAC. Acceptable feed-in grid frequency range will be 47.5-53.5Hz.</p> <p>Mode 5: Acceptable feed-in grid voltage range will be 100-280VAC. Acceptable feed-in grid frequency range will be 47.5-53.5Hz.</p> <p>Grid Feed Enable: OFF/ON Grid Feed Current: Default 20A</p>																				
 <p>Grid Setting</p> <table border="1"> <thead> <tr> <th>Setting Parameter</th> <th>Current Value</th> <th>Set Value</th> <th></th> </tr> </thead> <tbody> <tr> <td>Input Voltage Range</td> <td>APL</td> <td>APL</td> <td><input checked="" type="checkbox"/></td> </tr> <tr> <td>Grid-Connected Regulation</td> <td>Mode 04</td> <td>Mode 04</td> <td><input checked="" type="checkbox"/></td> </tr> <tr> <td>Grid Feed Enable</td> <td>OFF</td> <td>OFF</td> <td><input checked="" type="checkbox"/></td> </tr> <tr> <td>Grid Feed Current</td> <td>10A</td> <td>10A</td> <td><input checked="" type="checkbox"/></td> </tr> </tbody> </table> <p>Grid Setting page 1/2</p>	Setting Parameter	Current Value	Set Value		Input Voltage Range	APL	APL	<input checked="" type="checkbox"/>	Grid-Connected Regulation	Mode 04	Mode 04	<input checked="" type="checkbox"/>	Grid Feed Enable	OFF	OFF	<input checked="" type="checkbox"/>	Grid Feed Current	10A	10A	<input checked="" type="checkbox"/>	
Setting Parameter	Current Value	Set Value																			
Input Voltage Range	APL	APL	<input checked="" type="checkbox"/>																		
Grid-Connected Regulation	Mode 04	Mode 04	<input checked="" type="checkbox"/>																		
Grid Feed Enable	OFF	OFF	<input checked="" type="checkbox"/>																		
Grid Feed Current	10A	10A	<input checked="" type="checkbox"/>																		
 <p>Grid Setting</p> <table border="1"> <thead> <tr> <th>Setting Parameter</th> <th>Current Value</th> <th>Set Value</th> <th></th> </tr> </thead> <tbody> <tr> <td>External CT Function</td> <td>Enable</td> <td>Enable</td> <td><input checked="" type="checkbox"/></td> </tr> <tr> <td>Zero Export To CT</td> <td>500 W</td> <td>500 W</td> <td><input checked="" type="checkbox"/></td> </tr> <tr> <td>AC CHA Open Time</td> <td>0.00</td> <td>0.00</td> <td><input checked="" type="checkbox"/></td> </tr> <tr> <td>AC CHA Stop Time</td> <td>0.00</td> <td>0.00</td> <td><input checked="" type="checkbox"/></td> </tr> </tbody> </table> <p>Grid Setting page 2/2</p>	Setting Parameter	Current Value	Set Value		External CT Function	Enable	Enable	<input checked="" type="checkbox"/>	Zero Export To CT	500 W	500 W	<input checked="" type="checkbox"/>	AC CHA Open Time	0.00	0.00	<input checked="" type="checkbox"/>	AC CHA Stop Time	0.00	0.00	<input checked="" type="checkbox"/>	<p>This page can be set</p> <p>External CT function: Configure external CT function Default: disable</p> <p>Zero output to CT: set the mains input power of 10W ~ 500W Default: 150W</p> <p>AC CHA Open Time: The value ranges from 0 to 23. AC CHA Stop Time: The value ranges from 0 to 23.</p>
Setting Parameter	Current Value	Set Value																			
External CT Function	Enable	Enable	<input checked="" type="checkbox"/>																		
Zero Export To CT	500 W	500 W	<input checked="" type="checkbox"/>																		
AC CHA Open Time	0.00	0.00	<input checked="" type="checkbox"/>																		
AC CHA Stop Time	0.00	0.00	<input checked="" type="checkbox"/>																		
	<p>Charging Settings menu</p>	<p>Charging Settings menu page</p>																			
	<p>This page can be set</p> <p>CHA Source Priority: Set the charging priority</p> <p>1.CSO: Solar energy will give priority to battery charging. Alternating current only charges the battery when solar power is not available.</p> <p>2.SNU: Solar and mains power will charge the battery at the same time.</p> <p>3.OSO: Solar energy will be the only source of chargers, whether there is AC or not.</p> <p>Note: If the inverter/charger is operating in battery mode, only solar energy can charge the battery. If there is enough solar energy, the solar energy will charge the battery.</p> <p>MAX Utility CHA CUR: MAX CHA Current is smaller than that in program in MAX Utility CHA CUR, the inverter will apply charging current from program MAX CHA Current for utility charger.</p> <p>MAX CHA Current: MAX CHA Current To configure total charging current for solar and utility chargers</p> <p>Solar Supply Priority: BLU solar power priority to provide energy to battery/LBU solar power priority to provide energy to the load.</p>																				
 <p>Charge Setting</p> <table border="1"> <thead> <tr> <th>Setting Parameter</th> <th>Current Value</th> <th>Set Value</th> <th></th> </tr> </thead> <tbody> <tr> <td>CHA Source Priority</td> <td>SNU</td> <td>SNU</td> <td><input checked="" type="checkbox"/></td> </tr> <tr> <td>MAX Utility CHA CUR</td> <td>30A</td> <td>30A</td> <td><input checked="" type="checkbox"/></td> </tr> <tr> <td>MAX CHA Current</td> <td>40A</td> <td>40A</td> <td><input checked="" type="checkbox"/></td> </tr> <tr> <td>Solar Supply Priority</td> <td>BLU</td> <td>BLU</td> <td><input checked="" type="checkbox"/></td> </tr> </tbody> </table> <p>Charge Setting page 1/1</p>	Setting Parameter	Current Value	Set Value		CHA Source Priority	SNU	SNU	<input checked="" type="checkbox"/>	MAX Utility CHA CUR	30A	30A	<input checked="" type="checkbox"/>	MAX CHA Current	40A	40A	<input checked="" type="checkbox"/>	Solar Supply Priority	BLU	BLU	<input checked="" type="checkbox"/>	
Setting Parameter	Current Value	Set Value																			
CHA Source Priority	SNU	SNU	<input checked="" type="checkbox"/>																		
MAX Utility CHA CUR	30A	30A	<input checked="" type="checkbox"/>																		
MAX CHA Current	40A	40A	<input checked="" type="checkbox"/>																		
Solar Supply Priority	BLU	BLU	<input checked="" type="checkbox"/>																		